

EUROLIVE F1220A

High-Performance, Active 125-Watt Monitor Speaker System with 12" Woofer, 1" Compression Driver and Feedback Filter

- High-performance, 125-Watt, active monitor system for live and playback applications
- Exceptional sound quality, wide frequency bandwidth and dynamic range
- Adjustable feedback filter and integrated limiter for ultimate system control and speaker protection
- Ultra-low noise Mic/Line input with Volume control and peak LED
- Dedicated 3-band EQ for perfect sound shaping
- Powerful 12" long-excursion driver provides incredibly deep bas and acoustic power
- High-resolution 1" HF driver for exceptional high-frequency reproduction
- Proprietary horn design for ultra-wide sound dispersion
- Integrated 35 mm pole socket for stand mounting and use as a PA system
- High-quality components and exceptionally rugged construction ensure long life
- Conceived and designed by BEHRINGER Germany



How many times have you been in a soundcheck, one finger in your ear, your thumb stabbing the air, trying to get the sound guy to put enough of your vocals in your passive floor monitor. Suddenly, as the band tears into the first tune, you realize all you're getting from your floor monitor is a muffled, annoying mess?

The F1220A is designed to make those experiences little more than mournful memories. This 125-Watt active monitor has its own EQ and volume, so you not only have control of the output, you can also tweak the highs, mids and lows for a sound that gives you a clear, true sense of your sound. It's a proven fact that the better you can hear yourself, the better you'll play— isn't it time you got active?

Great sound takes guts

Inside these loudspeakers is the equivalent of a 2-way electronic crossover, a graphic equalizer, a parametric equalizer, a mic preamp and two power amplifiers! A 12" long-excursion

driver delivers deep, punchy lows while a 1" titanium-diaphragm compression driver gives you clean, crisp highs. They all work together with 125 watts of handling power and don't need adjustments or a degree in sound engineering.

Triumphant transducers

Every stitch of these loudspeakers is built to deliver, but the fact is that their transducers (woofers and tweeters) are the only part you actually hear. While some manufacturers are okay with putting off-the-shelf transducers in their boxes, we custom-design and build ours from scratch. Not only do we wind our own voice coils, we grow the trees that are processed into the paper pulp that becomes the cones. We even machine the frames and backplates. BEHRINGER's quality is truly under control.

Speaking of control...

The F1220A doesn't just sound great. It also gives you instant control of your monitor mix, even in mid-performance—

Continued on next page



EUROLIVE F1220A

something passive monitors simply cannot deliver! Need more volume? Turn the LEVEL dial until the desired volume is reached without activating the CLIP LED. Sound too bassy or trebley? Just reach down and use the three-band EQ (HIGH, MID, LOW) to tailor a rich, exciting sound.

Anytime, anywhere you choose

This monitor doesn't just cater to musicians. It's excellent for anyone with a need to be heard! With just one F1220A and a microphone or MP3 player, you can set up an instant sound system. Thanks to the built-in preamp section, you can connect a dynamic mic directly to the F1220A and raise and lower the volume with the Level control. Suddenly, it's showtime in no time at all. The F1220 also has a 35-mm socket so you can easily mount it on a pole for use in a PA system.

We've even given you a line of defense against live sound's greatest enemy. If you're experiencing feedback, just press the FEEDBACK FILTER switch, then slowly turn the FREQUENCY dial until feedback is eliminated.

Continued on next page

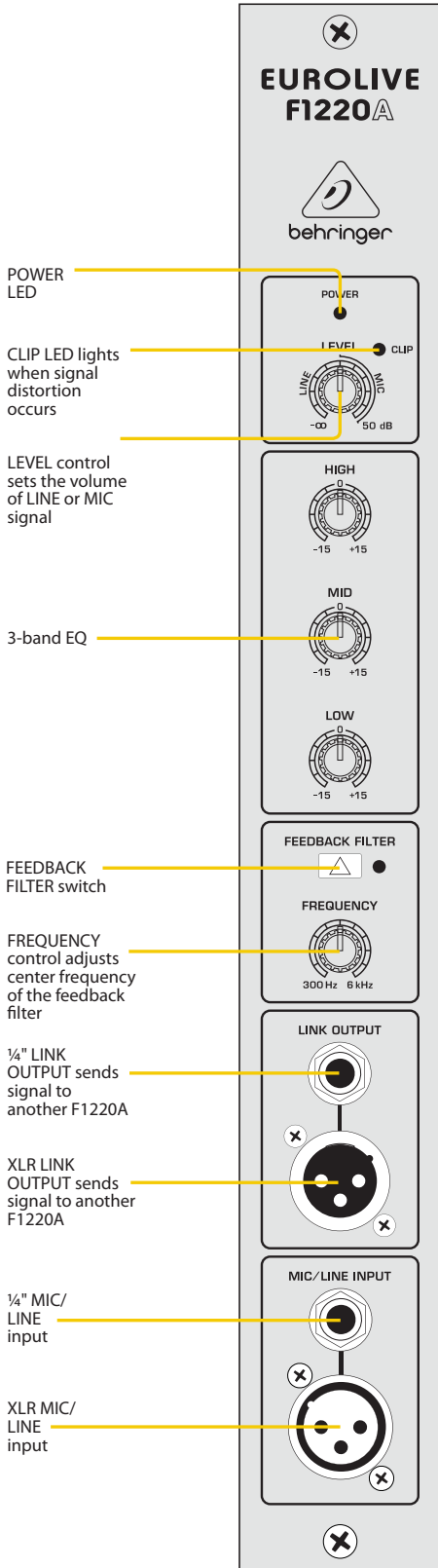

Live Setup with Two Keyboards

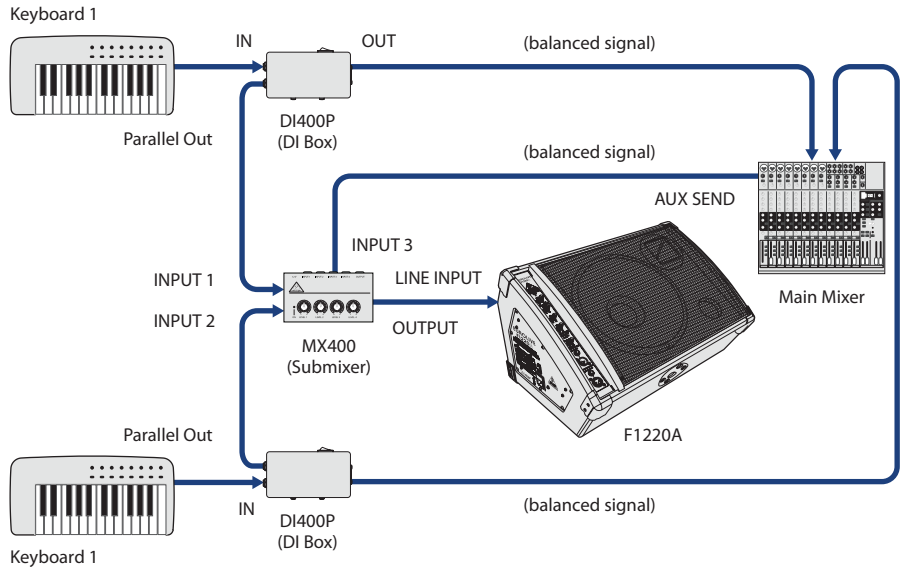

With Dynamic Microphone

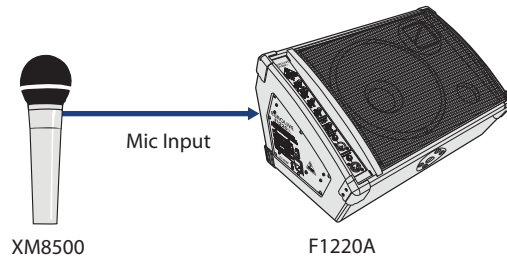

EUROLIVE F1220A

Awesome sound, unbelievable value

The F1220A is designed to give your next crazed rant/public announcement/synthesizer recital exactly the monitor or PA sound you want with minimal prep time. Suddenly a monitor sound that once was only available in a recording studio

is available in virtually any live setting. Loaded with a slew of incredible features but never loaded down by a heavy price tag, isn't just an excellent addition to your sound system; it's an excellent way to have enough cash left over to start buying all the other sound essentials.

SPECIFICATIONS

Output power

RMS @ 1% THD	90 W / 8 Ω
Peak power	125 W / 8 Ω

Input

XLR connector (servo-balanced)	—
Sensitivity	-50 dBu to +10 dBu
Input impedance	11 kΩ balanced; 30 kΩ unbalanced ¼" TRS jack (servo-balanced)
Sensitivity	-50 dBu to +10 dBu
Input impedance	11 kΩ balanced; 30 kΩ unbalanced

Link output

XLR connector	—
---------------	---

Loudspeaker system data

Frequency response	60 Hz to 18 kHz (-10 dB)
Maximum sound pressure level	121 dB @ 1 m
Limiter optical	—

Equalizer

LOW	80 Hz / ±15 dB
MID	2.5 kHz / ±15 dB
HIGH	12 kHz / ±15 dB

Feedback filter

Filter frequency	300 Hz to 6 kHz
Level reduction	max. 15 dB

Power supply

Power consumption	max. 180 W
-------------------	------------

Mains voltage / Fuse

100 - 120 V~ (50/60 Hz)	T 2.5 A H 250 V
220 - 230 V~ (50/60 Hz)	T 1.25 A H 250 V
Mains connector	standard IEC receptacle

Physical/weight

Dimensions (H x W x D)	approx. 14.2 x 22.8 x 16" approx. 360 x 580 x 406 mm
Weight	approx. 39.7 lbs/approx. 18 kg