

POWERPLAY 16 P16

P16-M — 16-Channel Digital Personal Mixer

- 16-channel digital stereo mixer to create your personal monitor mix
- Ultra-intuitive “analog” operation with total recall and 16 presets for custom mixes
- State-of-the-art 24-bit D/A converters for premium audio quality
- 16 Channel Select buttons with dual LEDs for perfect overview
- Level and Pan/Spread control per channel with LED meter
- 3-band EQ per channel with mid-band frequency control
- Solo and Mute functions per channel
- Global Level and EQ controls plus Panic Mute function
- High power and “drummer proof” headphones output
- Fully adjustable limiter protects your ears and headphones
- Additional mono/stereo line output to connect your powered monitor
- MIDI IN port for real-time remote control of all channels by external MIDI device such as BEHRINGER BCF2000, BCR2000, etc.
- Standard CAT5e connection delivers power and 16 signals to each Personal Mixer
- ULTRANET connector to daisy-chain up to forty-eight P16-M mixers for large systems (in conjunction with P16-D)
- Ultra-low system latency of less than 1 millisecond



The BEHRINGER POWERPLAY P16 system is the easy, affordable way to give your musicians and vocalists what they really want—“more me!” P16-M Personal Mixers lets each performer take control of what they hear, allowing the engineer to concentrate on providing the audience with the best possible listening experience. Fast and easy to set up, a basic system can be installed and configured in a matter of minutes—and the system can be expanded to adapt to changing needs.

Tech-Free Zone

The P16-M’s simple user interface makes it easy for even non-techie to dial-in the perfect monitor mix. For example, let’s say the electric guitar is too loud in the lead vocalist’s mix; they simply press the appropriate channel button (the one labeled E. GTR) and turn the Volume control to lower the guitar level in their mix. They can also adjust Pan (left to right mix), EQ (Bass, Mid with sweepable Freq control and Treble), and much more. All of these adjustments can be made without affecting anyone else’s personal mix.

Continued on next page



POWERPLAY 16 P16

- Powered via external power supply (included) or P16-I / P16-D
- Mounts easily on a mic stand with the P16-MB mic stand mount (not included)

P16-I — 16-Channel 19" Input Module with Analog and ADAT Optical Inputs

- Converts 16 analog inputs into 24-bit digital audio to be transmitted via standard CAT5e cable
- 2 x 8-channel ADAT optical inputs with auto detect and priority select
- 16 balanced, high-headroom TRS audio inputs
- State-of-the-art 24-bit A/D converters for premium audio quality
- 4-position gain switches per channel pair (-10, 0, +4, +22 dB)
- Digital inputs support 44.1 and 48 kHz sample rates
- Ultra-low system latency of less than 1 millisecond
- Signal Present and Clip LEDs per channel plus ADAT status LEDs
- Standard CAT5e connection delivers power and signals for up to 6 Personal Mixers
- ULTRANET expansion network connector (RJ45)
- Internal autorange power supply for maximum flexibility (100 – 240 V~), noise-free audio, superior transient response plus low power consumption for energy saving

Easy Installation

A basic installation consists of one P16-I audio interface, which connects to the main mixing console, and up to six P16-M Personal Mixers, creating a system big enough to equip a typical recording studio, a small to medium-sized band, or a worship team. You'll also need a few standard audio and CAT5 cables. The optional P16-MB mounting bracket allows the P16-M Digital Personal Mixer to be attached to any standard microphone, music or drum stand. The system can easily be expanded via the P16-D Digital

ULTRANET Distributor, six of which can be combined to drive up to forty-eight P16-M Personal Mixers.

Extraordinary Value

The POWERPLAY P16 puts total control of the monitor system where it belongs—in the hands of the performers, freeing up the engineer to sculpt the perfect front-of-house mix. The POWERPLAY P16 system is the easy, affordable way to tame runaway stage volume and give your musicians and vocalists what they really want—"more me!"

Continued on next page



POWERPLAY 16 P16

P16-MB — Mounting Bracket for P16-M

- Mounting bracket for P16-M Digital Personal Mixer
- Attaches to standard mic, music or drum stands

P16-D — 16-Channel Digital ULTRANET Distributor

- Distribution Hub for P16-I for system expansion
- 1 ULTRANET input feeds 8 ULTRANET outputs (RJ-45)
- Provides bus-power and 16-channel signal transmission for all 8 outputs
- Up to six P16-D ULTRANET Distributors can be combined for a total of forty-eight P16-M Personal Mixers
- Status LED indicators for RJ-45 input and 8 RJ-45 outputs
- Internal autorange power supply for maximum flexibility (100 - 240 V~), noise-free audio, superior transient response plus low power consumption for energy saving

Common Features

- Extremely rugged construction ensures long life even under the most demanding conditions
- Conceived and designed by BEHRINGER Germany

Front View Panel

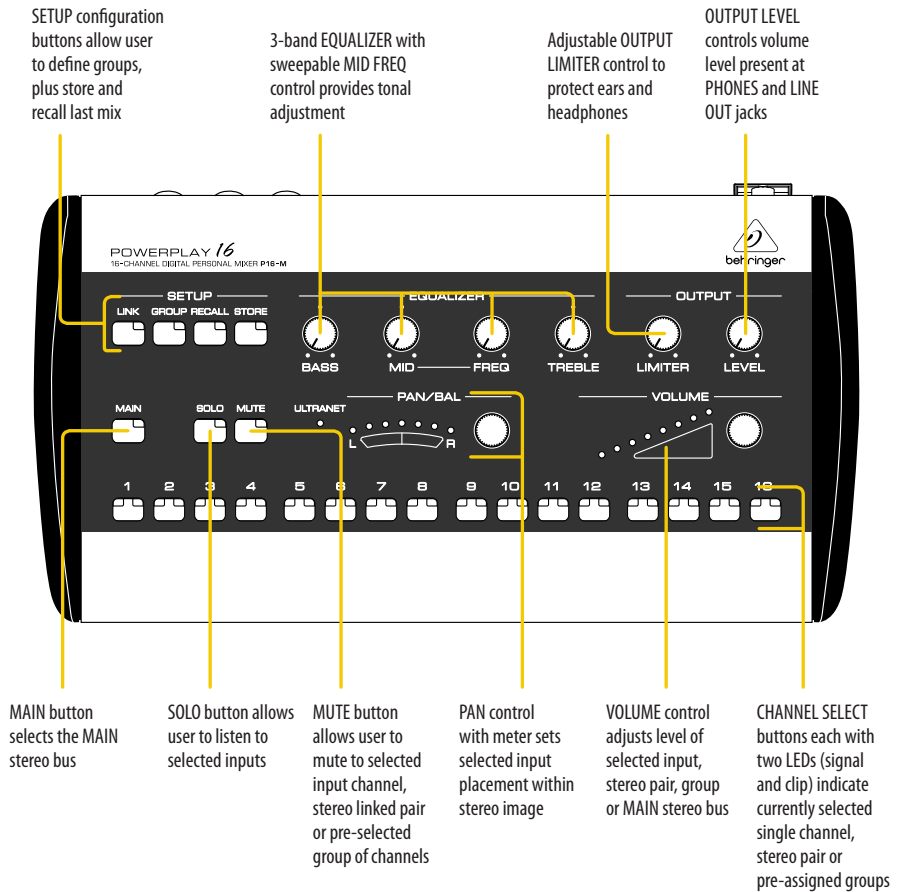

Rear View Panel

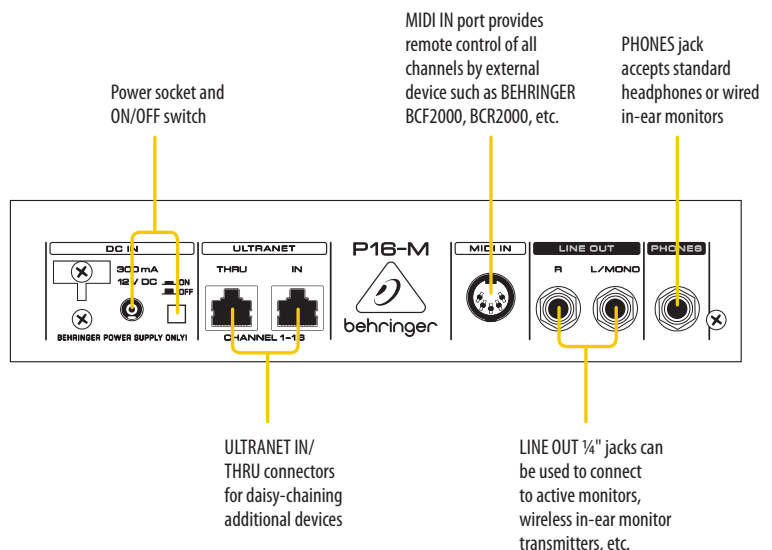

POWERPLAY 16 P16

Live Performance Recording Hook-up

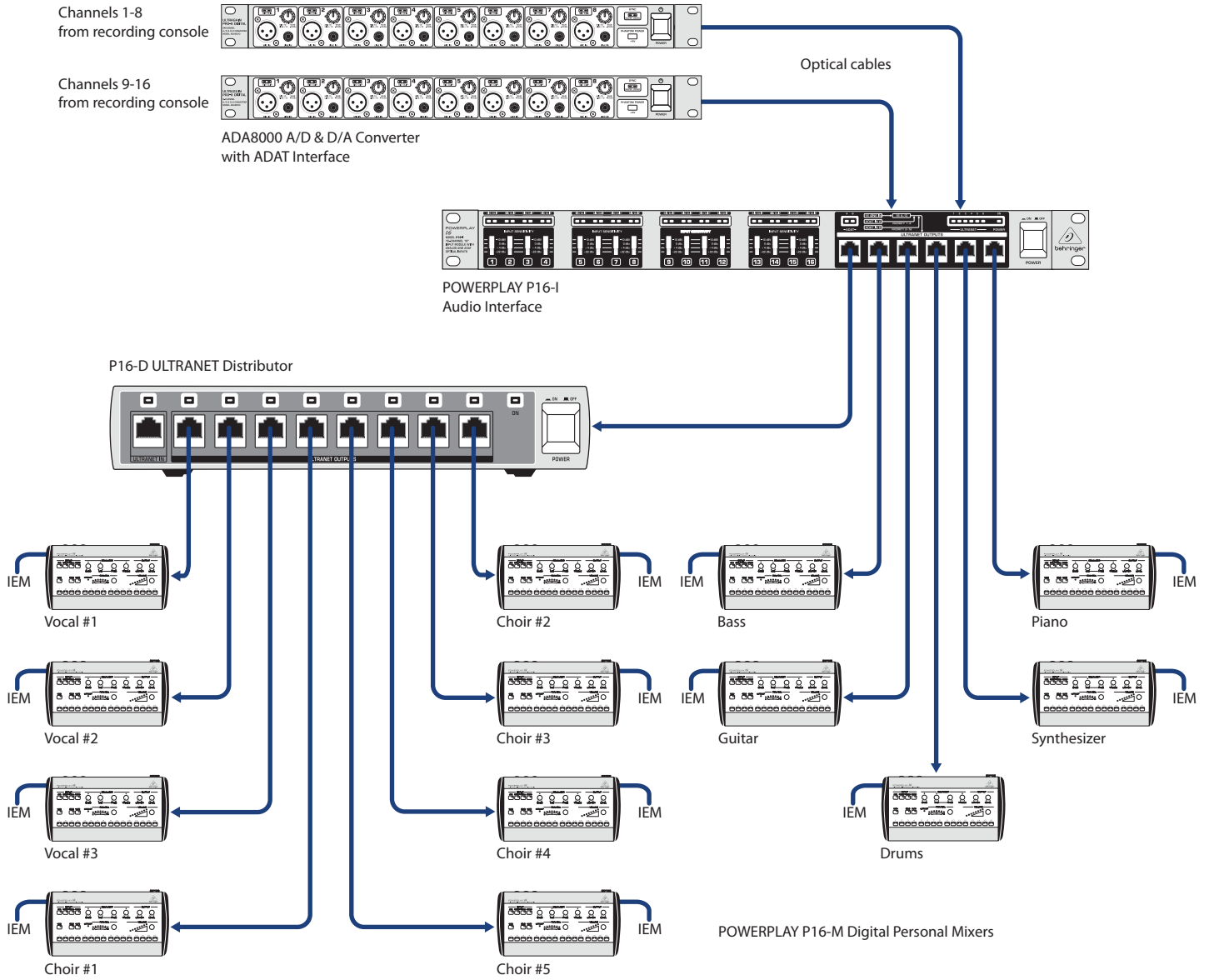

POWERPLAY 16 P16

Basic Personal Monitor Hookup

