

## Professional Powered Speakers

# EUROLIVE VQ1800D VQ1500D

### Professional Active 500-Watt 18/15" PA Subwoofer With Built-In Stereo Crossover

- Professional 500-Watt powered subwoofer for PA applications
- Powerful 18/15" long-excursion transducer with high temperature voice coil provides incredibly accurate and pulse-pounding bass
- Precise reproduction of ultra-low frequencies for "bulletproof" punch and impact
- State-of-the-art 500-Watt Class-D amplifier with comprehensive over-excursion, thermal and clip limit protection
- Built-in active stereo crossover provides high-pass filtered outputs for full-range loudspeakers
- Tunable and switchable Bass Boost plus Phase switch for ultimate low-frequency performance
- Variable High Cut control for perfect sound alignment
- Subwoofer Level control to adjust the balance between subwoofer and the full-range speakers
- Power, Signal and Clip LEDs for perfect monitoring
- Intelligent limiter for maximum sound performance and woofer protection
- Internal switch-mode power supply for noise-free audio, superior transient response and very low power consumption
- Pole socket for mounting with commercial spacer poles
- Ergonomically shaped handles for easy transport
- Rugged steel grill for optimal speaker protection



EUROLIVE VQ1800D and VQ1500D active subwoofers are ideal for adding serious bottom end to DJ and club rigs. Packed with an incredible array of professional features, these little powerhouses provide lots of low-end punch, with the kind of definition and clarity typically reserved for much larger systems.

Class-D amplifiers (with switch-mode power supplies) drive the custom-designed low frequency drivers for sonically optimized output. Best of all, VQ1800D and VQ1500D subs provide a much better power-to-weight ratio than many competing active subwoofers. Powered by 500 Watts both the 18" and 15" versions feature custom-designed transducers made in our own factory.

Put simply, these cool-running systems are powerful and lightweight, making them easy to transport and set up—and our no-compromise design means you get amazingly-tight, chest-pounding bass that will keep the party going all night. Adding VQ1800D and VQ1500D subwoofers

will transform your active full-range loudspeakers into a powerful PA system with serious dynamic punch.

#### Class-D Technology

Instead of operating relatively continuously like Class AB circuits, Class-D amps are either fully on or fully off, significantly reducing power losses given off as heat. Less heat generation means our amps don't need massive heat sinks and all that unnecessary added weight. Our no-compromise design allows VQ Series subwoofers to deliver full power with incredible fidelity all night long.

When used in conjunction with switching-mode power supplies, which don't require huge and heavy transformers, our VQ Series' Class-D amplifiers provide tremendous punch and superior fidelity. The resulting speaker systems are much lighter, making them easy to transport and set up.

*Continued on next page*



# EUROLIVE VQ1800D VQ1500D

## Custom-Designed Transducers

The transducers (woofers and tweeters) are the only part of a sound system you actually hear, so we don't cut corners. We custom-design and build our transducers from scratch. Not only do we wind our own voice coils—we even process the paper pulp into cones and machine our own back plates. This enables us to control the quality, and frankly, make better components.

## Take Control

The VQ1800D and VQ1500D feature balanced XLR inputs and outputs, as well as balanced XLR Thru jacks for connecting additional enclosures. A Boost Frequency

knob targets a frequency between 40 Hz and 90 Hz. Flick the Boost switch to give your selected frequency a +6 dB boost. These subs also feature a High Cut dial to control the upper corner frequency (70 – 150 Hz) for the subwoofer's amplifier. The High Cut dial does not affect the Thru or Output signals, only the signals directed to the subwoofer. A Level knob controls the Input gain, and the Phase switch reverses output phase to compensate for frequency cancellation between the subwoofer and satellite speakers. LEDs show operational status at a glance, including Power, Signal present and Limit.

## Which Speaker Do I Need?

As you have probably noticed, we make VQ Series subwoofers in two different woofer sizes. Which one is right for you? Bass speakers, such as the kind used in

subwoofers, create punch and impact by moving air. An 18" woofer has about 30% more surface area than a 15", so it can move a much larger column of air. If you're running sound for a small jazz combo in a nightclub, a single VQ1500D might be all you'll need. But, if you're providing a pulse-pounding dance mix to a large standing room only crowd, you might need a pair of VQ1800Ds, or more to get the job done.

## Value

Power, portability and amazing sound quality; you get it all with the EUROLIVE VQ1800D/VQ1500D—at an equally amazing price. Check out these low-frequency marvels at your BEHRINGER dealer or order them from your favorite online retailer. The experience will move you!

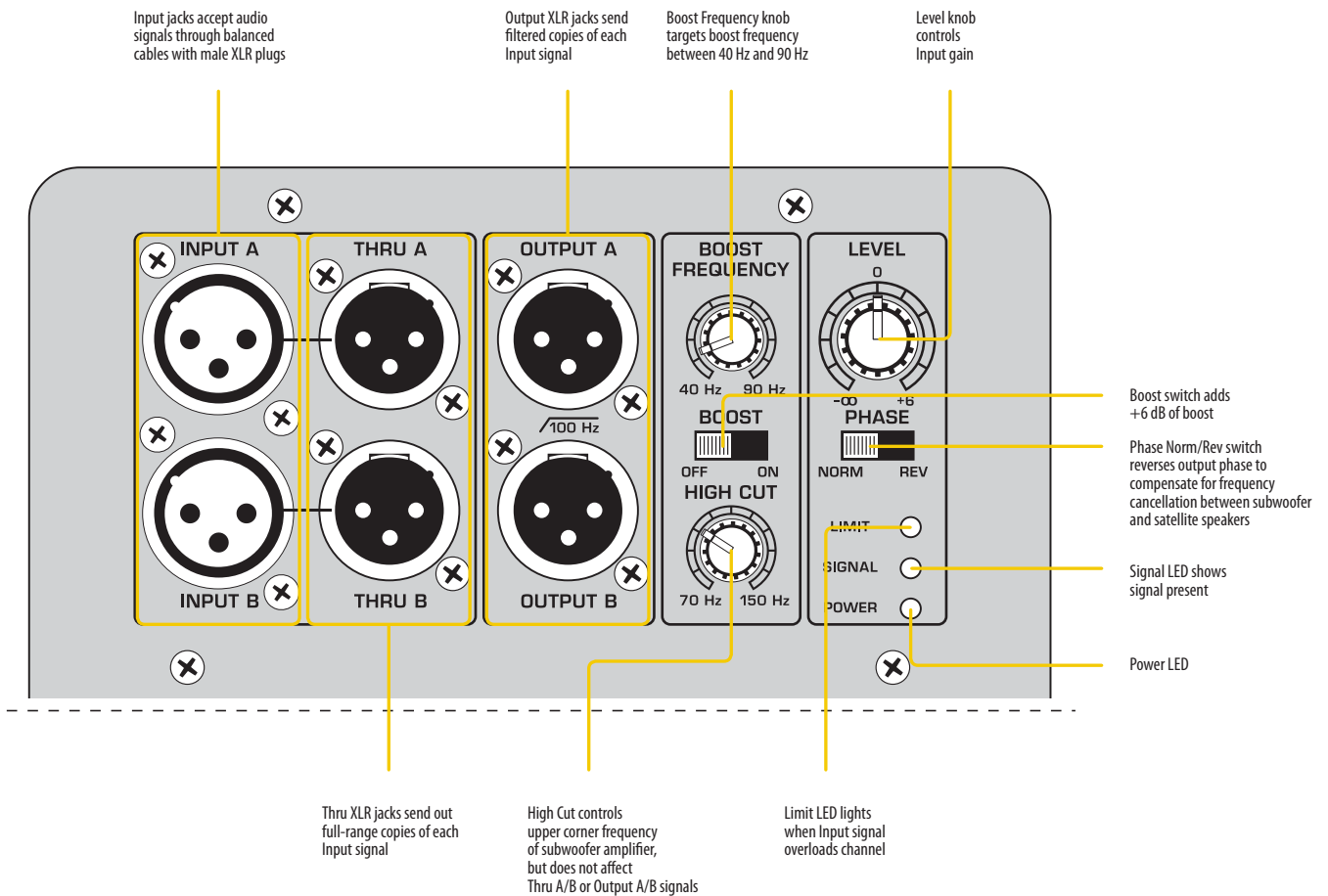

# EUROLIVE VQ1800D VQ1500D

## Single Subwoofer with Stereo Mains

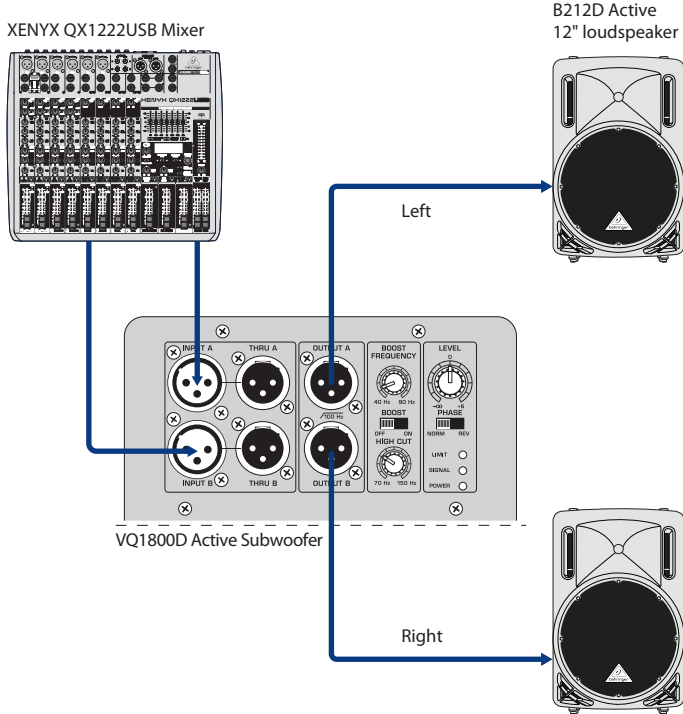

## Active Stack Application

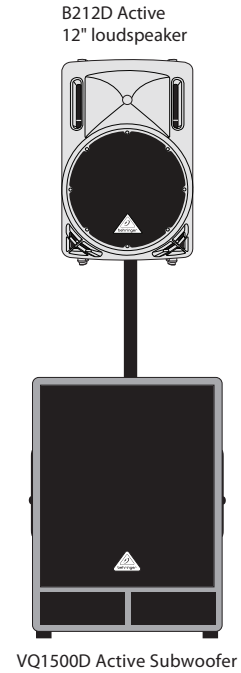

## Dual Subwoofers with Stereo Mains

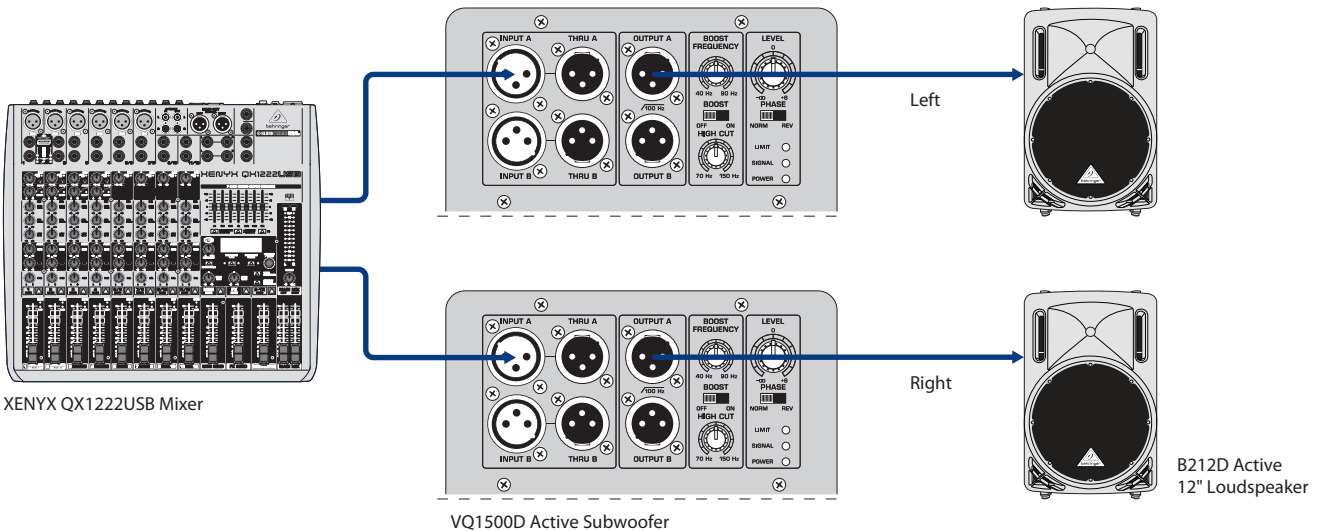

# EUROLIVE

## VQ1800D

## VQ1500D

### Specification

	VQ1800D	VQ1500D
<b>Amplifier</b>		
Maximum output power	500 W *	
<b>Audio Inputs</b>		
Input A / B	XLR, servo-balanced	
Sensitivity	+4 dBu @ 0 dB (center position) for full rated power	
Input impedance	12 k $\Omega$ unbalanced, 24 k $\Omega$ balanced	
<b>Audio Outputs</b>		
Thru A / B	XLR, servo-balanced	
Output A / B	XLR, servo-balanced	
Output impedance	300 $\Omega$ unbalanced, 600 $\Omega$ balanced	
High-pass filter	100 Hz, Butterworth, 18 dB slope	
<b>Controls</b>		
Level	- $\infty$ to +6 dB	
Boost frequency	40 Hz – 90 Hz; +10 dB	
Boost	Switchable	
High cut	70 – 150 Hz, Butterworth, 24 dB slope	
Phase	Switchable	
<b>System Data</b>		
Frequency range	40 Hz – 200 Hz (-10 dB)	40 Hz – 200 Hz (-10 dB)
Frequency response	60 Hz – 150 Hz (+/-3 dB)	65 Hz – 150 Hz (+/-3 dB)
Signal-to-noise (20 Hz to 20 kHz)	>100 dB	
Sound pressure level (half space)	max. 124 dB @ 1 m	max. 122 dB @ 1 m
Woofers	456 mm / 18", 8 $\Omega$	387 mm / 15", 8 $\Omega$
Limiter	Optical	
<b>Indicators</b>		
Signal LED	Green	
Limit LED	Red	
Power LED	Amber	
<b>Circuit Protection</b>		
Amplifier protection	Full short circuit, open circuit, thermal protection	
<b>Power Supply, Voltage (Fuses)</b>		
USA / Canada	120 V~, 60 Hz (T 6.3 A H 250 V)	
UK / Australia / Europe	220-240 V~, 50/60 Hz (T 3.15 A H 250 V)	
Korea / China	220-240 V~, 50/60 Hz (T 3.15 A H 250 V)	
Japan	100 V~, 50/60 Hz (T 6.3 A H 250 V)	
Power consumption @ 1/2 max power	110 W	
Mains connection	Standard IEC receptacle	
<b>Dimensions / Weight</b>		
Dimensions (H x W x D)	670 x 528 x 566 mm (26.4 x 20.8 x 22.3")	616 x 490 x 528 mm (24.3 x 19.3 x 20.8")
Weight	38.2 kg (84.1 lbs)	33.1 kg (72.8 lbs)

\*Independent of limiters and driver protection circuits

For service, support or more information contact the BEHRINGER location nearest you:

**Europe**  
MUSIC Group Services UK

**USA/Canada**  
MUSIC Group Services NV Inc.

**Japan**  
MUSIC Group Services JP K.K.