



VRX932LAP

12" Two-Way Powered Line Array Loudspeaker System

Key Features:

- ▶ Built-in JBL DrivePack® DPC-2 amplifier module designed by Crown provides 1750 Watts of peak power. DSP-based resident input module provides system optimization and EQ.
- ▶ JBL's exclusive neodymium magnet Differential Drive® woofer for high-power capacity and light-weight.
- ▶ VRX932LAP features 3 x 2408J Annular Ring Diaphragm HF drivers. The 2408 represents the latest in JBL Professional compression driver design.
- ▶ Constant Curvature waveguide for unprecedented array coherence.
- ▶ Integral rigging hardware for simple connection of enclosures and optional array frame. Dual angle pole socket for aiming flexibility.
- ▶ Array Configuration Selector permits "array shading".

Application:

- ▶ Music playback and sound reinforcement in mid-size venues.
- ▶ Entertainers, corporate A/V professionals and sound system hire companies.
- ▶ Permanent Installation.

The VRX932LAP is a powered, light-weight, compact 12" two-way line-array speaker system designed for use in arrays of up to five units. VRX932LAP is the ideal choice when line-array performance is needed but the venue size doesn't call for the very long-throw characteristics of larger line-arrays and a fast and easy setup is vital.

The Constant Curvature waveguide mounts three compression drivers on a continuous arc. When additional VRX932LAP speakers are added to the array the uninterrupted arc continues. In effect, all the drivers work together as if they were a single driver on a very long waveguide. Since there are three drivers in each VRX932LAP, the combined power handling and acoustic output of the system is far greater than a single driver could achieve.

VRX932LAP uses "amplitude shading" to shape the coverage of the array. Switches on the input plate allow, for example, the upper box in an array to reach a distant balcony while the lower box is shaded back to reduce excessive level at the front of the listening area. This yields to a more coherent sound field and less feedback problems.

One or two VRX932LAP's may also be used on a tripod or over subwoofers. The integrated rigging hardware is used to securely lock the array together while the dual-angle pole socket provides aiming flexibility.

As many as five VRX932LAP speaker systems may be suspended in a single array for a nominal vertical coverage of up to 75°. Suspended applications require the JBL VRX-AF array frame or eye bolts (available separately).



The VRX932LAP is compatible with VRX918SP/VRX918S and SRX781S subwoofers. The VRX932LAP is manufactured and sold under U.S. patents 5,748,760; 6,112,847; 6,394,223; 6,847,726; 6,768,806; 6,774,510; and D483,743

Specifications:

Frequency Range (-10 dB):	57 Hz - 20 kHz
Frequency Response (±3 dB):	75 Hz - 20 kHz
Coverage Pattern:	100° x 15° nominal
Maximum Peak Output ¹ :	136 dB SPL at 1m
LF Driver:	1 x JBL 2262FF 305 mm (12 in) dual voice coil Differential Drive® woofer with neodymium-magnet
HF Driver:	3 x JBL 2408J, 38 mm (1.5 in) voice coil neodymium compression driver
Bandpass Nominal Impedance:	LF: 2 x 2 ohms HF: 4 ohms
DPC-2 Internal Amplification Output (at nominal load):	1750 Watts Peak, 875 Watts Continuous
DPC-2 Output as (Continuous IEC shaped pink noise into rated load impedance):	LF: 750 Watts, HF: 125 Watts
DPC-2 Output Section:	LF: Dual-Bridged Technology™, Class D HF: Bridged Class D
Audio Input Connector:	XLR with loop through
User Controls:	Input Attenuator (0-16 dB) ACS (Array Configuration Selector), HF level adjustment (+3 dB, 0 dB, -3dB)
Signal Processing:	DSP based, resident in Input Module
System Management:	DSP based limiters for mechanical and thermal protection.
AC Power Operating Range:	90-132 VAC or 216-264 VAC, 50/60Hz
AC Line Voltage:	User selectable: 120V/240V (-15%, +10%)
AC Input Connector:	Neutrik PowerCon (NAC 3MPA)
AC Loop Through Connector:	Neutrik PowerCon (NAC 3MPB)
AC Current Requirements:	6A per system at 120V, 3A per system at 240V
Enclosure:	25/15 mm birch plywood.
Suspension / Mounting:	Optional VRX-AF line-array frame kit, 10mm forged eyebolts or internal dual angle 36mm pole mount cup for pole or tripod mounting
Finish:	Black DuraFlex™ finish
Grille:	Powder coated, black, 16-gauge perforated steel with acoustically transparent foam
Dimensions (H x W x D):	349 mm x 597 mm x 444 mm (13.75 in x 23.5 in x 17.5 in)
Net Weight:	24 kg (52 lb)
Optional Accessories:	VRX-AF array frame, eyebolt kit part #229-00017 SS2-BK tripod speaker stand SS3-BK satellite speaker pole SS4-BK adjustable satellite speaker pole to be used with the VRX918SP and SRX718S only.

¹ Measured with IEC shaped noise in free field conditions.

JBL continually engages in research related to product improvement. Some materials, production methods and design refinements are introduced into existing products without notice as a routine expression of that philosophy. For this reason, any current JBL product may differ in some respect from its published description, but will always equal or exceed the original design specifications unless otherwise stated.

► VRX932LAP 12" Two-Way Powered Line Array Loudspeaker System

Block Diagram

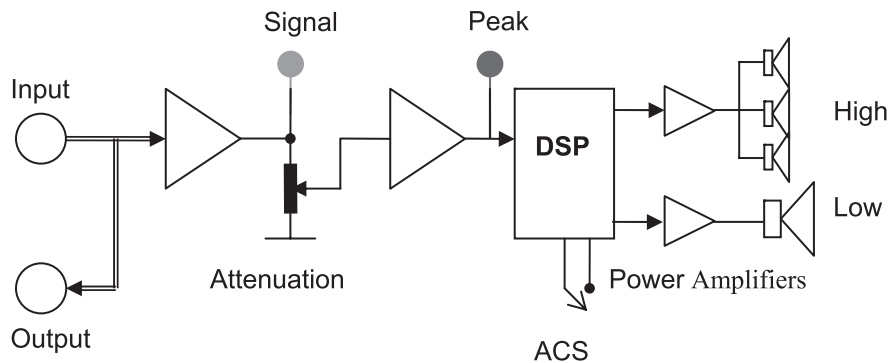

Array Configuration Selector (ACS)

Amplitude shading is a technique that allows the coverage pattern of a loudspeaker array to be shaped by adjusting the relative acoustic output of some of the devices in the array. Most often, array shading involves only the mid and high-frequency sections of the array. In a simple system consisting of three VRX932LAP's, the lower speaker (which covers the nearest listeners) may have its high-frequency output reduced. At the same time, the upper speaker may have its high frequency output increased. The overall sound-power in the room is unchanged but the distribution of acoustic energy to the audience is far more uniform.

The -3 dB position of the HF output level selector will typically be used for the speaker(s) in an array that are covering the nearest listening area. The +3 dB position will be used for the speaker(s) covering the more distant areas, or to compensate for the low-frequency build-up resulting from mutual coupling of multiple woofers in an array.

For single speaker applications the -3 dB HF-output level is recommended for best tonal balance.

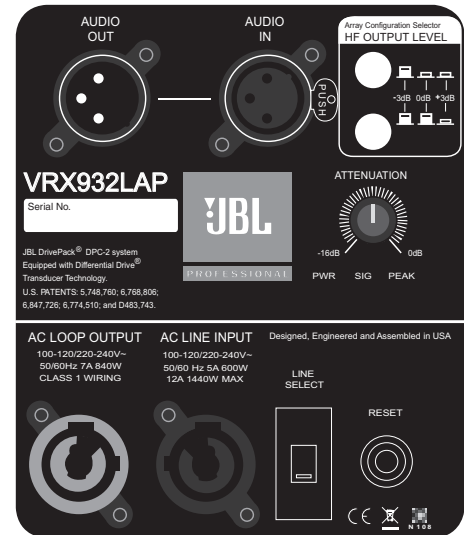

VRX-AF Array Frame Accessory

The VRX-AF is an array frame kit designed to be used for suspension of the VRX932LAP line array loudspeaker. The optional array frame kit includes an array frame, four quick release pins, a pair of forged 3/8" shackles, and a pair of drop levers.

The following table defines the maximum number of speakers that may be suspended using the VRX-AF. A minimum design factor of 7:1 is maintained for all speakers configuration at or below those indicated in the table:

Maximum number of VRX918SP in array:	0	2	3	3	4	4
Maximum number of VRX932LAP in array:	5	4	3	2	1	0



For some applications, it may be necessary to pull back the array from the bottom in order to achieve the desired coverage. Every VRX-AF is supplied with a spare set of quick release pins and a pair of spare drop levers that are used to adapt a second array frame to the bottom of a VRX932LAP array. Once these are installed on the bottom enclosure, the array frame may be attached as previously described.

Ground-Stacked, Upward Firing Arrays: Applications such as covering stadium bleachers from the playing field may be addressed by installing the VRX-AF array frame to the bottom of the array as described above. Up to four VRX932LAP loudspeakers may be locked together and ground stacked using the VRX-AF array frame kit, as shown.

Dimensions

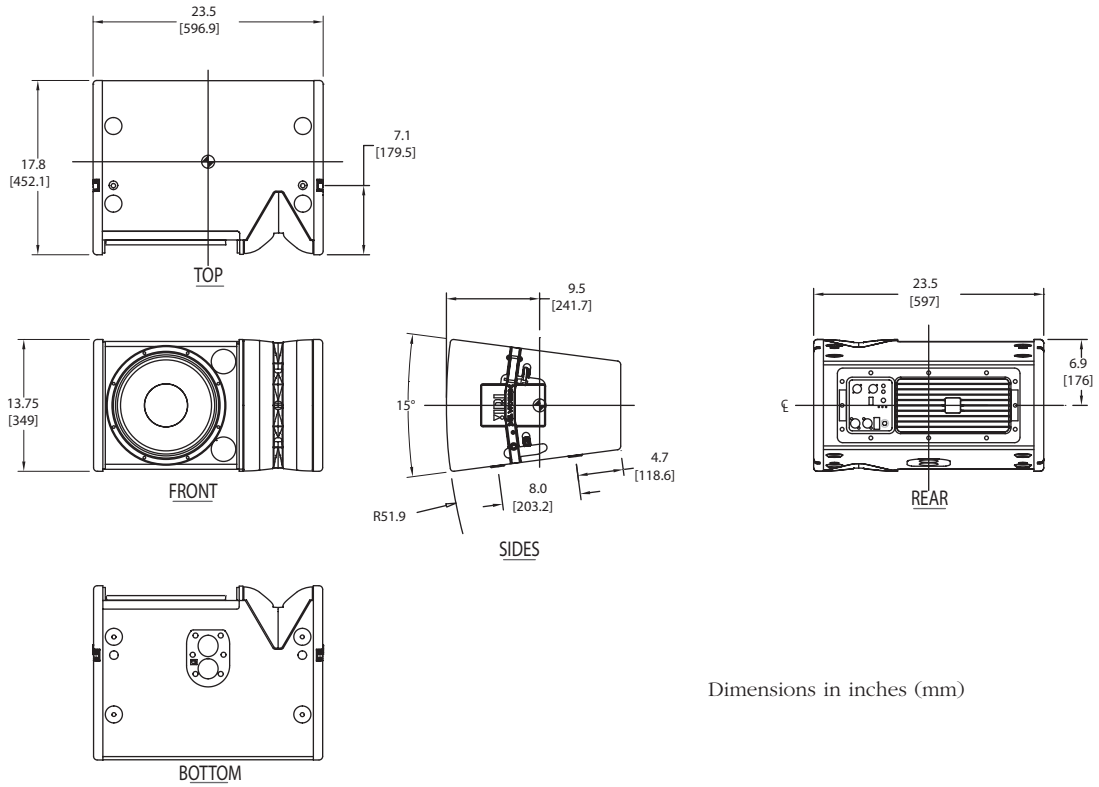

Dimensions in inches (mm)

System Configurations



With SS2-BK

With subwoofers and SS4-BK

Ground-stacked with VRX-AF

Suspended with VRX-AF

► VRX932LAP 12" Two-Way Powered Line Array Loudspeaker System

Frequency Response

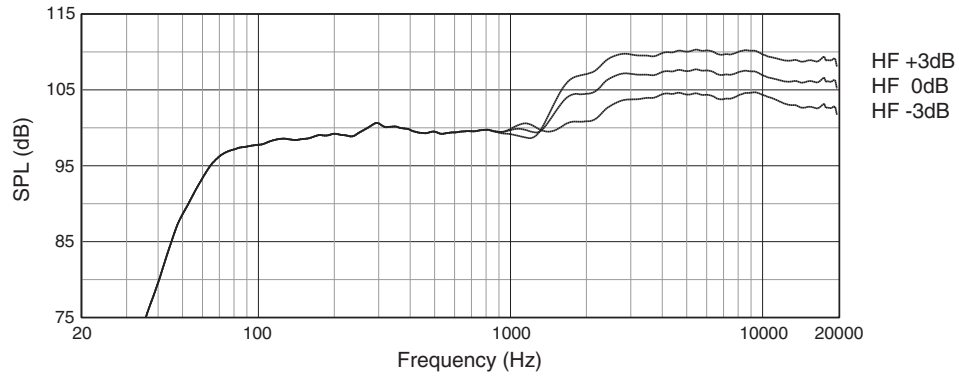

Horizontal Beamwidth

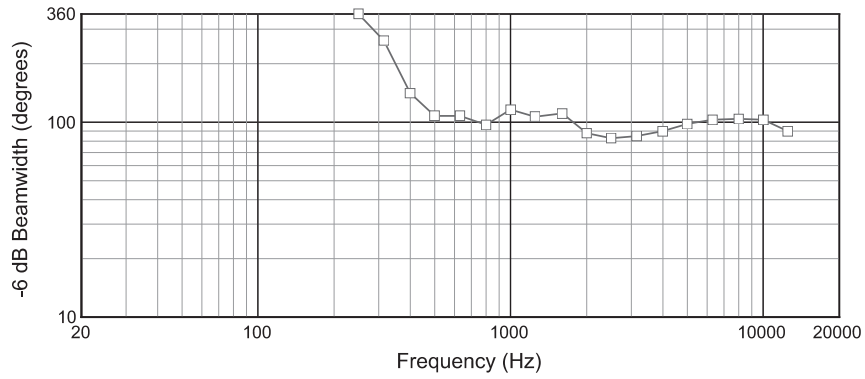

Vertical Beamwidth

