



## Technical Specifications



# DUAL DIAPHRAGM CONDENSER MICROPHONE B-2 PRO

Gold-Sputtered Large Dual-Diaphragm Studio  
Condenser Microphone

# DUAL DIAPHRAGM CONDENSER MICROPHONE B-2 PRO

## Gold-Sputtered Large Dual-Diaphragm Studio Condenser Microphone

- Professional 1" gold-sputtered dual-diaphragm condenser microphone for unsurpassed audio quality
- Ideal as main and support microphone for studio and live applications--perfect for acoustic instruments and overhead etc.
- Selectable cardioid, omnidirectional or figure eight pickup pattern
- Pressure-gradient transducer with shock-mounted gold-sputtered dual-diaphragm capsule
- Switchable low-frequency roll-off and input attenuation
- Ultra low-noise transformerless FET input eliminates low-frequency distortion
- Gold-plated 3-pin XLR output connector for highest signal integrity
- Rugged construction with satin nickel-plated brass body
- Heavy-duty suspension mount, windscreen and aluminum transport case included
- High-quality components and exceptionally rugged construction ensure long life
- Conceived and designed by BEHRINGER Germany

## Specifications

Transducer type	condenser, 1" dual-diaphragm
Operating principle	pressure gradient
Polar pattern	cardioid, omnidirectional or figure eight
Connection	gold-plated balanced XLR connector

### Open Circuit Sensitivity (at 1 kHz)

cardioid	-36 dBV (0 dBV = 1 V/Pa), 16 mV/Pa
omnidirectional	-37 dBV (0 dBV = 1 V/Pa), 14 mV/Pa
figure eight	-35 dBV (0 dBV = 1 V/Pa), 18 mV/Pa
Frequency response	20 Hz - 20 kHz
Level attenuation	-10 dB (switchable)
Low-Cut filter	6 dB/oct. at 150 Hz (switchable)

### Max. SPL (1% THD @ 1 kHz)

cardioid	138 dB (0 dB), 148 dB (-10 dB)
omnidirectional	139 dB (0 dB), 149 dB (-10 dB)
figure eight	137 dB (0 dB), 147 dB (-10 dB)

### Equivalent SPL (IEC 651)

cardioid	17 dB-A
omnidirectional	18 dB-A
figure eight	16 dB-A

### Signal-to-Noise Ratio

cardioid	77 dB, A-weighted
omnidirectional	76 dB, A-weighted
figure eight	78 dB, A-weighted
Nominal impedance	<100 Ω
Load impedance	>1 kΩ

### Mains Voltage/Fuse

Supply voltage	+48 V
Supply current	3 mA

### Physical/Weight

Dimensions	Ø head: 56 mm, Ø shaft: 50 mm, length: 210 mm
Weight	approx. 0.55 kg

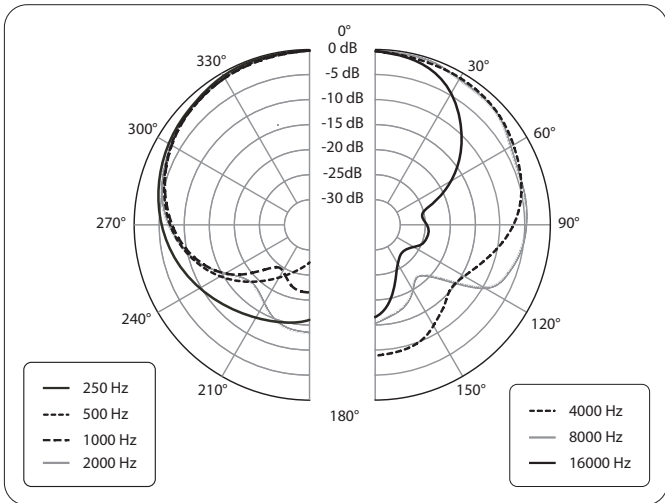

Polar pattern (cardioid)

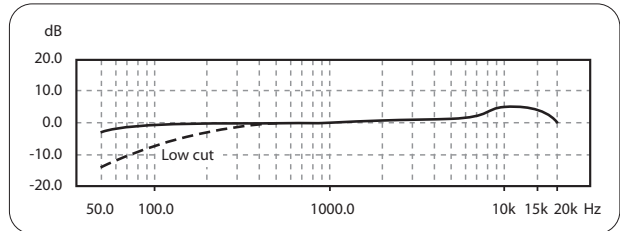

Frequency response (cardioid)

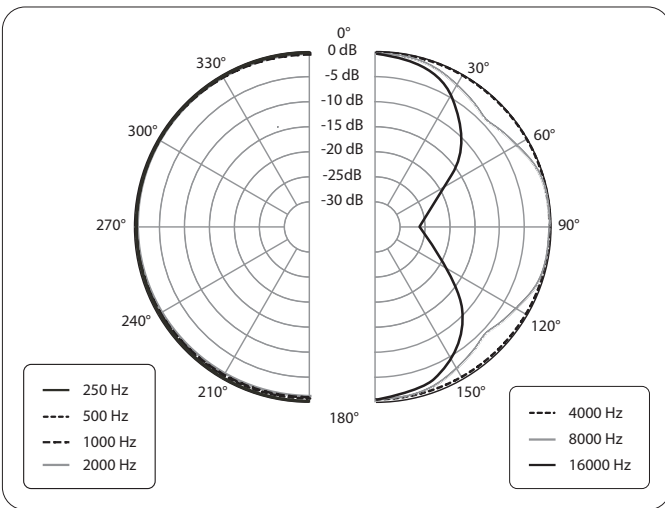

Polar pattern (omnidirectional)

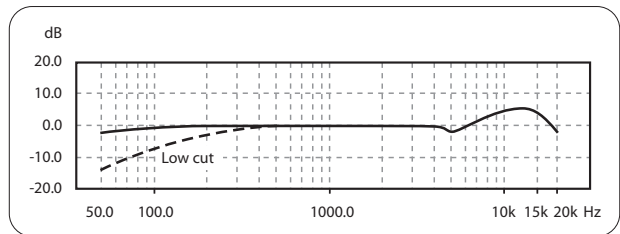

Frequency response (omnidirectional)

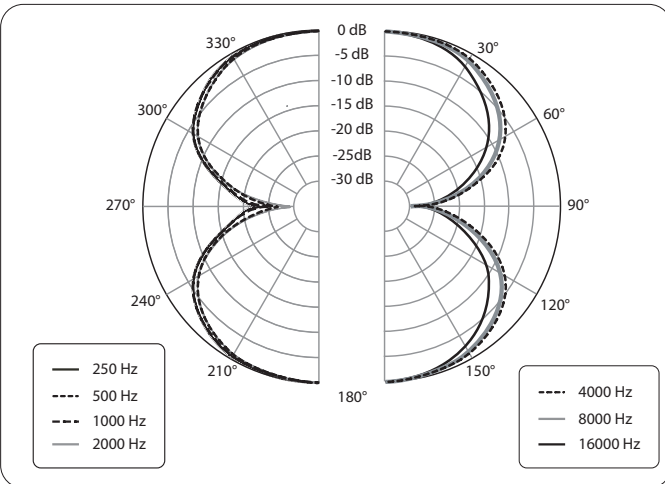

Polar pattern (figure eight)

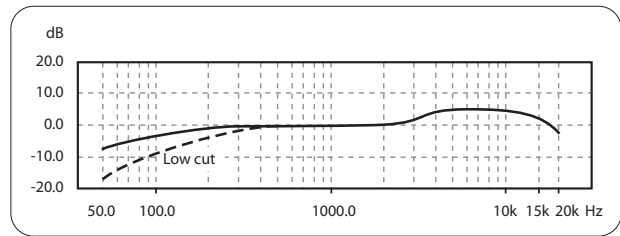

Frequency response (figure eight)