

Digital Mixers

X32 COMPACT

POWERED BY MIDAS

Compact 40-Input, 25-Bus Digital Mixing Console with 16 Programmable MIDAS Preamps, 17 Motorized Faders, Channel LCD's, 32-Channel Audio Interface and iPad/iPhone* Remote Control

- Compact 40-input channel, 25-bus digital mixing console for Studio and Live application
- 16 MIDAS-designed, fully programmable mic preamps for audiophile sound quality
- 17 Fully automated motorized 100 mm faders allow for instant overview, powerful scene management and DAW control
- 8 XLR outputs plus 6 additional line in/outputs, 2 phones connectors and a talkback section with integrated or external mic
- Individual and dynamic LCD Scribble Strips on all channels and buses creating easy assignment and intuitive channel distinction
- 32 x 32 channel USB 2.0 audio interface, with DAW remote control emulating HUI* and Mackie Control*
- iPad* and iPhone* apps for professional remote operation available free of charge—no host PC required
- High-resolution 7" day-viewable Color TFT for easy viewing of workflow components and parameters
- Main LCR, 6 matrix buses and all 16 mix buses each featuring inserts, 6-band parametric EQ's and full dynamics processing, plus 8 DCA and 6 mute groups
- Virtual FX rack featuring 8 true-stereo FX slots include high-end simulations such as Lexicon 480L* and PCM70*, EMT250* and Quantec QRS* etc.



X32 COMPACT

Compact 40-Input Channel, 25-Bus Digital Mixing Console with 16 Programmable MIDAS Preamps, 17 Motorized Faders, Channel LCD's, FireWire*/USB Audio Interface and iPad/iPhone* Remote Control

Lean Mean Mixing Machine

What happened to the X32? It's there... just a little bit smaller. The X32 COMPACT delivers the best of the flagship X32 console in a slightly smaller package for installs at smaller venues, houses of worship, theaters or discerning audiosmiths who may not need as many local inputs or motorized faders.

Powered by MIDAS & KLARK TEKNIK

When we began development on the X32 COMPACT, we called on our sister companies, MIDAS and KLARK TEKNIK, recognized the world over for their digital consoles and EQ/FX processing, for implementation support. The programmable, high-grade mic preamps found in the X32 COMPACT are based on a genuine MIDAS design, all the way down to their A/D converters. The resulting design ensures superior common mode rejection ratio (CMRR) and extremely low harmonic distortion (THD). The X32 COMPACT is an amazingly clean amalgam of high technology merged with superb user-friendly features.



We also received brilliant support from MIDAS and KLARK TEKNIK in designing X32 COMPACT's GUI (graphical user interface), a major advancement in digital mixing made easy, productive, and well... fun! They also drew on their extensive experience in FPGA (Field Programmable Gate Array) coding for rock-solid, ultra-low latency digital channel patching—giving the X32 COMPACT the capacity to handle up to 168 sources on 168 destinations, including the two AES50 ports. You can expect to see more collaboration between BEHRINGER and MIDAS in the very near future.

You're Well Connected

Ultimate connectivity remains the battle cry of the X32 COMPACT with its 40 inputs, 25 buses, 16 programmable MIDAS-designed mic preamps, FireWire* and USB 2.0 recording capability. Not sure which X32 is right for you? We totally get it. That's why the entire X32 family is designed to be beautifully scalable through the powerful AES50 ports built right in. Connect the powerhouse S16 digital snakes to these inputs to add an additional 16 mic preamps to your setup.

Travel Light... Travel Far

Need another X32 for side of stage or the broadcast control booth? X32 COMPACT packs all the features with the same great 7" TFT screen and customizable LCD scribble strip so you can take on the world of sound with all the firepower you'll ever need – without hauling a world of outboard gear and analog snake cables.



- 40-Bit floating-point DSP features "unlimited" dynamic range with no internal overload and near-zero overall latency (0.8 msec)
- Powerful scene management for convenient handling of complex productions
- 48-channel Digital Snake ready** via dual AES50 ports, featuring KLARK TEKNIK's SuperMAC networking capability for ultra-low jitter and latency
- USB type-A connector providing file storage and uncompressed stereo recordings plus show presets and system updates
- Dedicated and easy-to-use channel strip section with direct access controls and graphic user interface for intuitive workflow
- Additional user-definable control section allows to set up short-cuts to your favorite views or parameters
- ULTRANET connectivity for BEHRINGER's P-16 Personal Monitoring System** plus AES/EBU stereo digital output and MIDI
- Networked remote control for show setups with on-screen software editor via Ethernet
- Built-in expansion port for audio interface cards or digital networking bridges
- Future firmware updates, incl. new FX "Plug Ins", downloadable from behringer.com free of charge
- Conceived and designed by BEHRINGER Germany

Input Channel Preamp, Dynamics & EQ Panel

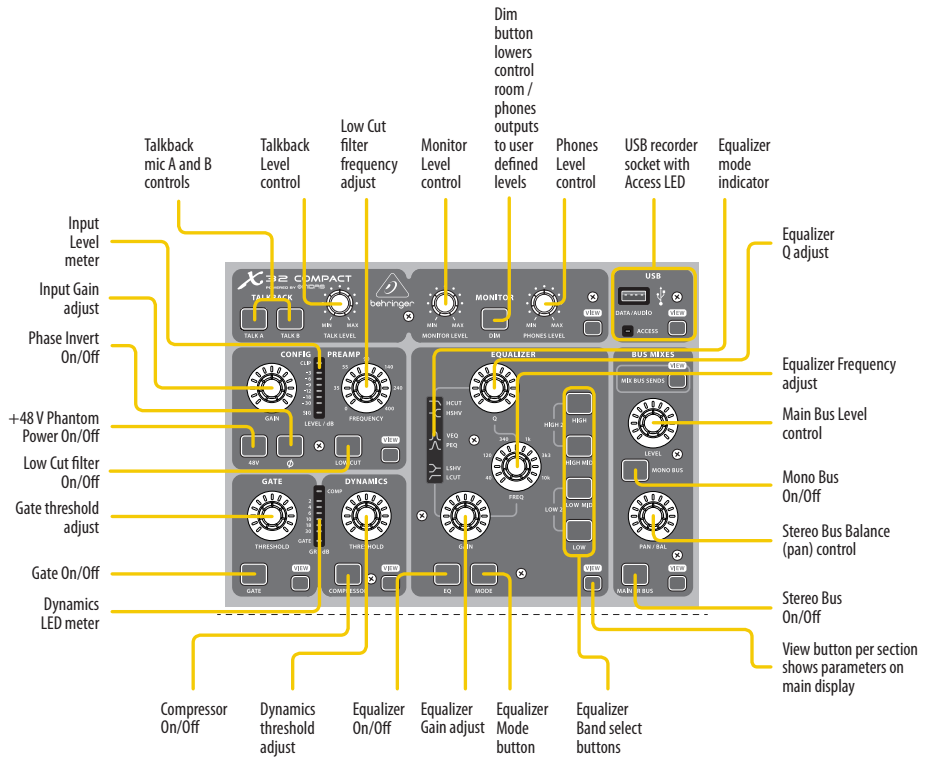

Main Display

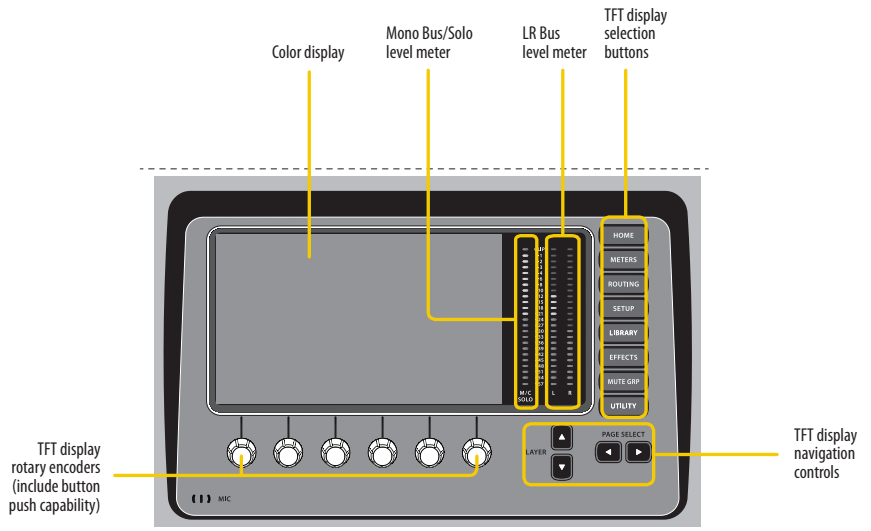



Input Channel Strip

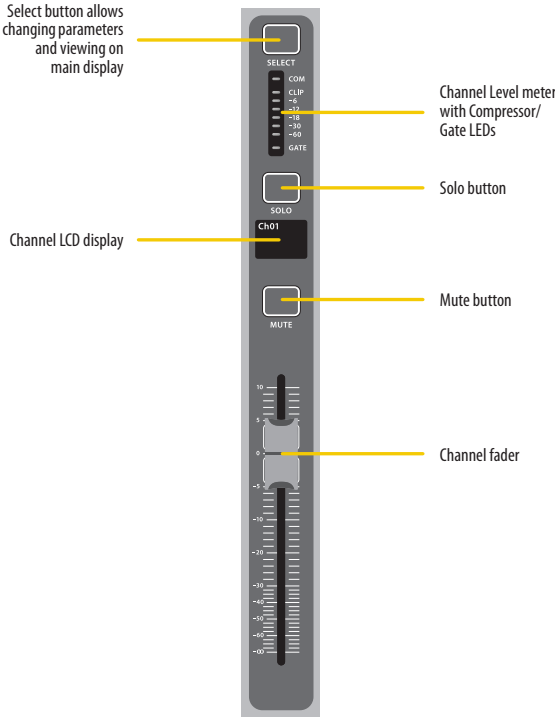

Output Channel Strip

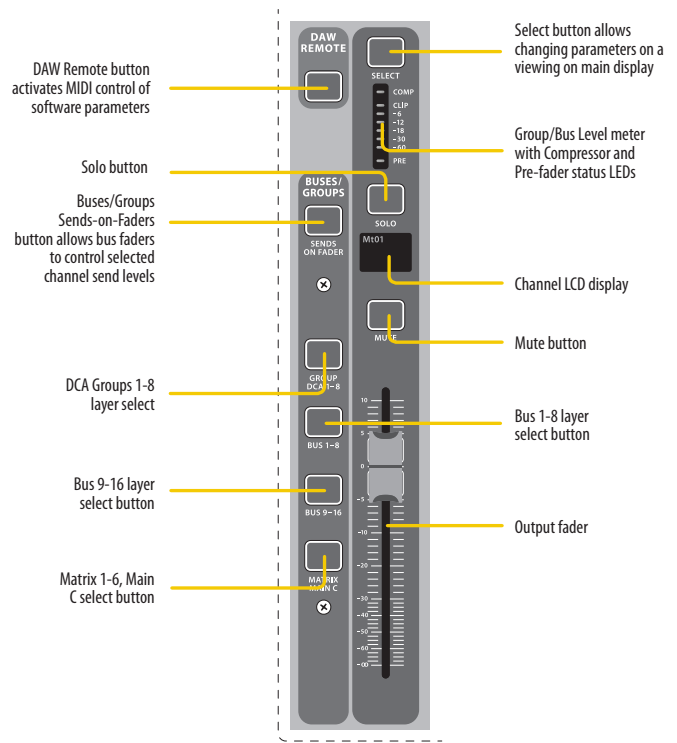

Rear Panel Input Patchbay

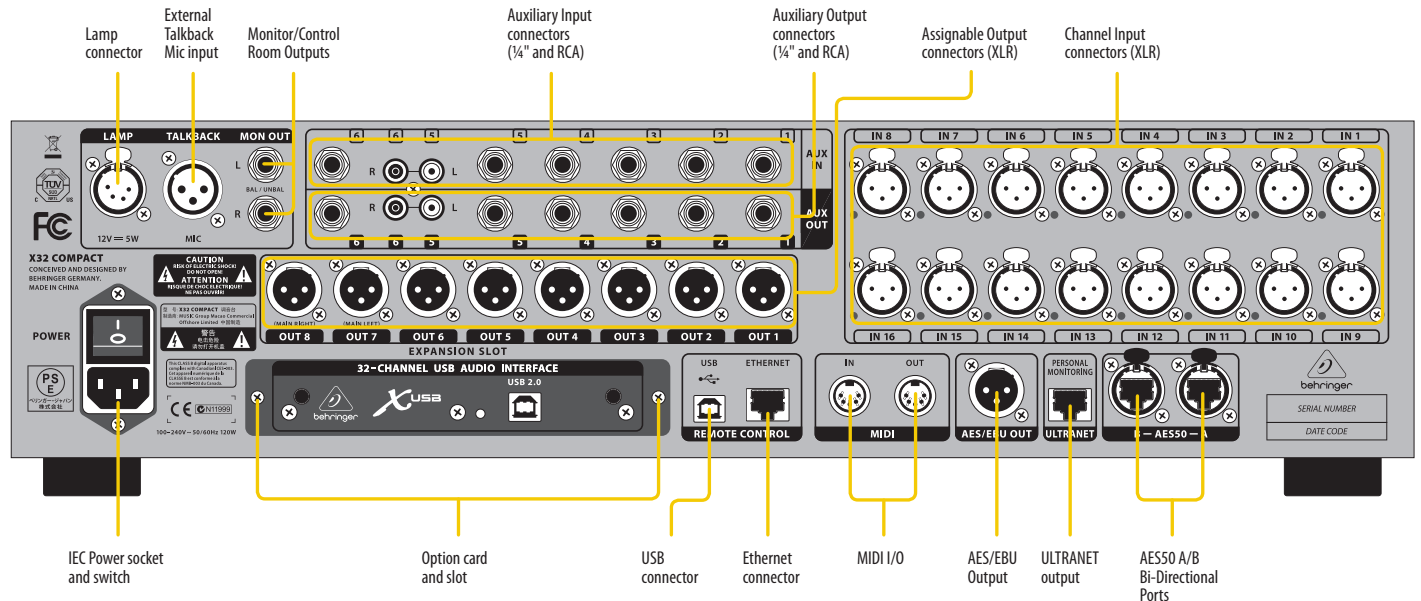



X32 COMPACT Setup with S16 and P16 Monitor System

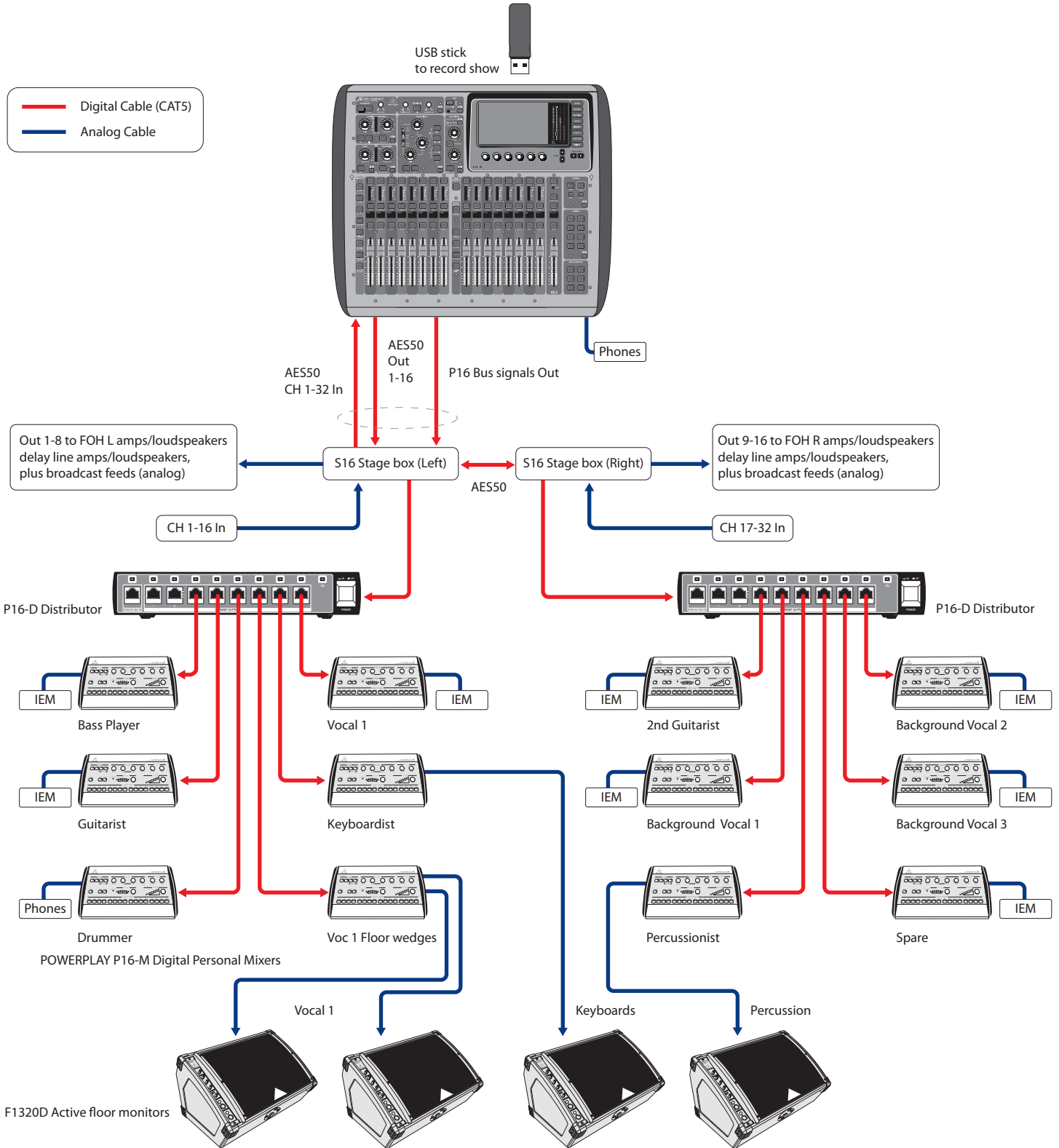



X32 COMPACT Recording Studio Setup

Control Room

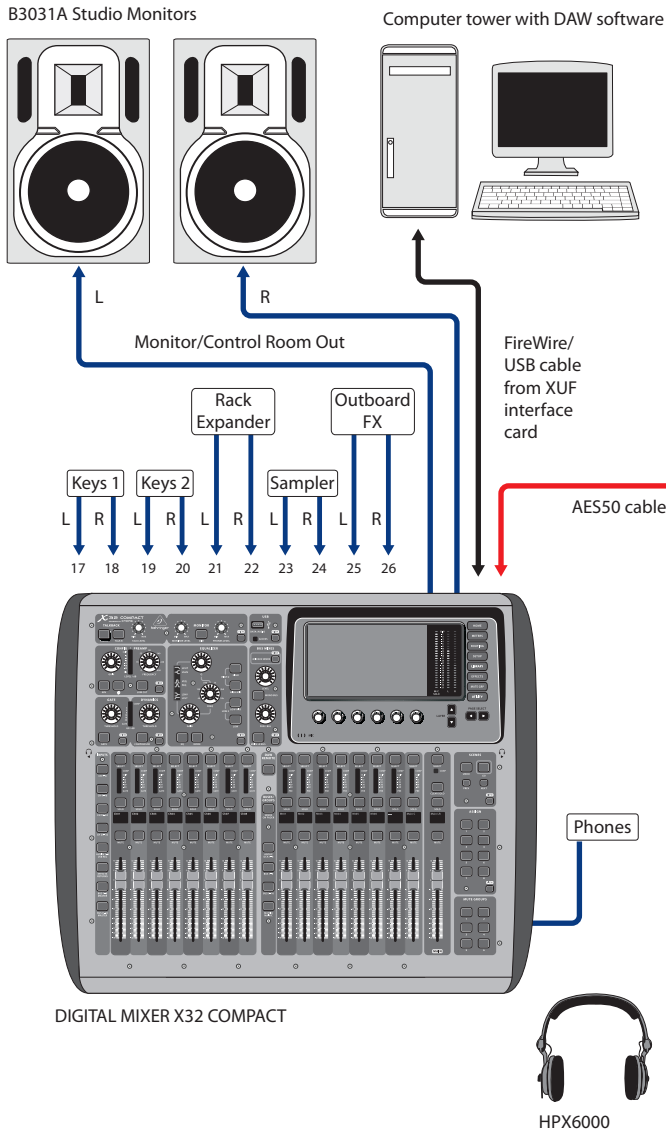

Recording Room

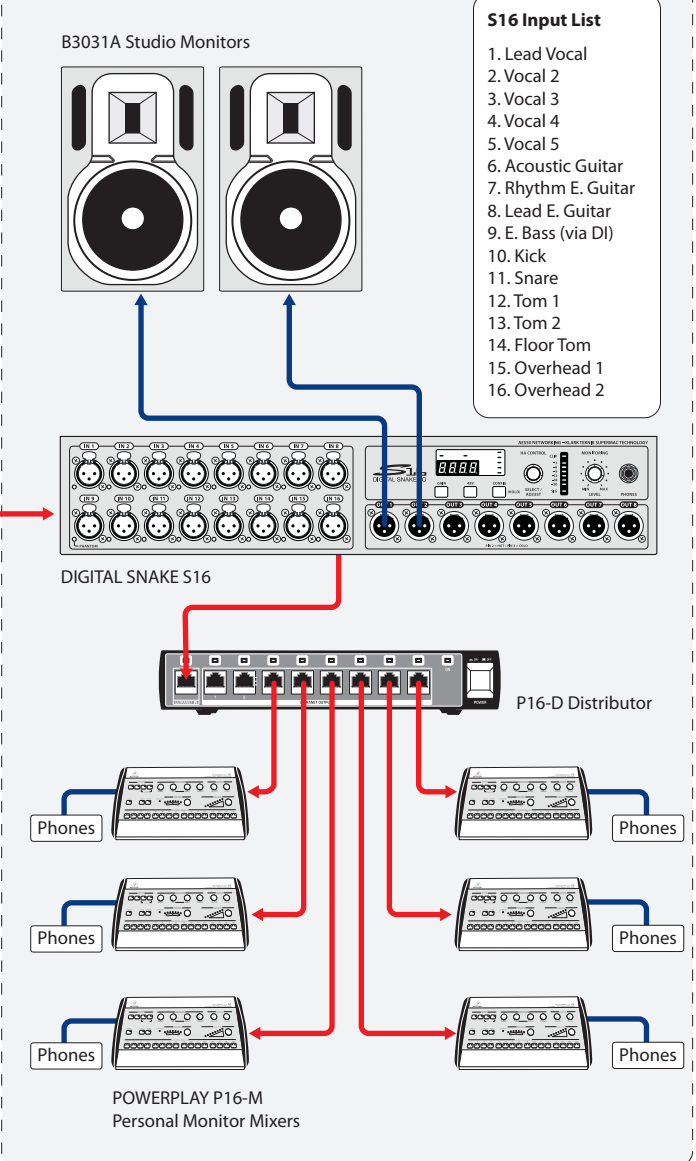

- S16 Input List**
1. Lead Vocal
 2. Vocal 2
 3. Vocal 3
 4. Vocal 4
 5. Vocal 5
 6. Acoustic Guitar
 7. Rhythm E. Guitar
 8. Lead E. Guitar
 9. E. Bass (via DI)
 10. Kick
 11. Snare
 12. Tom 1
 13. Tom 2
 14. Floor Tom
 15. Overhead 1
 16. Overhead 2



Specifications

Processing

Number of processing channels	32 input channels, 8 aux channels, 8 FX return channels, 16 aux buses, 6 matrices, main LRC
Internal effects engines, true stereo / mono	8 / 16
Internal total recall scenes (incl. preamp and fader)	100
Signal processing	40-bit floating point
A/D-D/A conversion (Cirrus Logic A/D CS5368, D/A CS4385)	24-bit @ 44.1 / 48 kHz, 114 dB dynamic range
Local I/O latency (local in > console processing* > local out)	0.8 ms
Network I/O latency (stagebox in > console processing* > stagebox out)	1.1 ms

Connectors

XLR inputs, programmable mic preamps, designed by MIDAS	16
Talkback mic input, XLR	1 external (plus internal mic)
RCA inputs/outputs	2/2
XLR outputs	8
Monitoring outputs ¼" TRS balanced	2
Aux inputs/outputs, ¼" TRS balanced	6/6
Phones outputs, ¼" TRS	2 (stereo)
Digital AES/EBU output, XLR	1
AES50 ports, SuperMAC	2
Expansion card slot	32 channel audio input/output, various standards
P-16 connector, Ultraset (no power supplied)	1
MIDI inputs / outputs	1/1
Ethernet, RJ45, rear panel, for remote control	1
USB Type A, top panel, for audio and data export/import	1
USB Type B, rear panel, for system updates	1

Mic Input Characteristics

Preamp design	MIDAS
THD + noise, 20 dB gain, 0 dBu out	< 0.006% A-weighted
Input impedance XLR jack, unbal. / bal.	5 kΩ / 10 kΩ
Non clip maximum input level, XLR	+23 dBu
Phantom power, switchable per input	48 V
Equivalent input noise level, XLR (input shorted)	-128 dBu
CMRR, XLR, @ 20 dB gain (typical)	> 70 dB
CMRR, XLR, @ 40 dB gain	> 80 dB

Input/Output Characteristics

Frequency range, @ 48 kHz sample rate, 0 dB to -1 dB	10 Hz - 22 kHz
Dynamic range, analog in to analog out (typical)	106 dB
A/D dynamic range, preamp to converter (typical)	109 dB
D/A dynamic range, converter and output	108 dB
Cross talk rejection @ 1 kHz, adjacent channels	100 dB
Output level, XLR, nom./max.	+4 dBu / +21 dBu
Output impedance, XLR, unbal. / bal.	75 Ω / 75 Ω
Input impedance TRS jack, unbal. / bal.	20 kΩ / 40 kΩ
Non clip maximum input level, TRS	+16 dBu
Nominal output level, TRS	+4 dBu / +16 dBu
Output impedance, TRS, unbal. / bal.	150 Ω / 300 Ω
Phones output impedance / level	40 Ω / +25 dBm (stereo)
Residual noise level, XLR and TRS	-87 dBu (A-weighted)

Display

Main screen	7", 800 x 480, 262k color TFT
Channel LCD screen (17 pcs)	128 x 64, LCD with RGB color backlight
Main meter	24-segment (-57 dB to clip)

Power

Switch-mode power supply	Autorange 100-240 V (50/60 Hz)
Power consumption	120 W

Physical

Standard operating temperature range	5°C – 40°C (41°F – 104°F)
Dimensions	215 x 625 x 510 mm (8.5 x 24.6 x 20")
Weight	15.4 kg (33.9 lbs)

*including all channel and bus processing, excluding insert effects and line delays

Please note these specifications are preliminary and conceptual in nature, and as such are subject to change as product development progresses. This information is supplied for market research purposes only and is not to be made public in any manner. This document is solely the property of The MUSIC Group, or one of its subsidiaries, and must be surrendered upon request of the owner.

For service, support or more information contact the BEHRINGER location nearest you: