

MYSTYQUE 400 DMX



CONTENTS

Warning.....	1
Important safeguards.....	3
Caution.....	4
Please note:	4
Important.....	4
Figure 1 DMX HAZE Functions	5
Description	6
Getting ready	7
Mounting	6
Set Up	8
DMX Connector Pin Assignment	8
Functions of the buttons	9
Very Important	11
Operation	11
Figure 2 DMX Chart	16
Troubleshooting.....	17
Maintenance	19
Product Specification	20

If the supply cord is damaged, it must be replaced by the manufacturer, its service agent or similarly qualified persons in order to avoid a hazard.

Instructional icons



Read the manual



Indoor use only



This symbol indicating separate collection for electrical and electronic equipment



Warning: situations that could cause injury to yourself or others



Caution: situations that could cause damage to your machine or other equipment



Note: notes, usage tips, or additional information

Thank you for selecting our DMX haze machine, you already own the high-tech, professional DMX haze! Better read the manual thoroughly before operation, follow instruction will help you have a smooth handling with DMX haze machine to achieve the most satisfactory haze effect, it will also assist unit to further prolong life time as a whole.



Warning!

Like all electronic products, DMX haze machine must be used with safety precautions in mind.



Fill enough fog fluid before plugging in, empty fluid tank when not in use or moving.

- Use only appropriate, grounded electric power supply for your unit. See your product specification label for appropriate power supply. This appliance must be earthed.
- Disconnect from electric mains power supply when not in use, when filling the fluid tank, or when changing a fuse. Keep unit dry. If moisture or liquids enter the haze machine case, immediately disconnect power supply. Contact a service technician to determine safety for use.
- Before moving the machine, always drain fog fluid and tighten the tank cap securely to avoid spilling.
- Without user-serviceable parts in the package, please contact your local agent or qualified technician for servicing.

- Without changeable structure by non-qualified user, please do not open the cover or have any change at will, otherwise, it may cause accident!
- Haze machine is for adult use. Keep out of reach of children. Never leave the unit running unattended.
- Haze machine nozzle gets hot over 200 degrees (centigrade) during use. Don't touch! Maintain a safe distance over 100CM. Never aim the nozzle directly at people.
- Keep case closed while operating. Put the machine in drafty place. Do not insert objects into air vents. Allow 100CM space or above around the machine for proper ventilation.
- Keep haze machine away from flames and flammable items. Never aim the nozzle at open flames or sparks. Use only high quality water-based haze fluid. Never put flammable substances into the tank.
- Machine must cool down before cleaning, servicing or storing.
- Never put any flammable material (lipid, gas, perfume etc.) into the tank, read the user manual thoroughly before operation.
- Better use our high quality water-based fog fluid, random use with other haze fluid may jam the pipe, or even erode the components inside.
- Keep sufficient fluid in tank. Operating the unit without sufficient fluid, the pump will stop working.

- If any abnormal running occurs, stop it immediately, empty the fluid, and bring the done up unit (recommend original box) to your agent or dealer for servicing. Make sure all fluid is empty from the tank before moving or shipping.
- Never drink fog fluid. If ingested, call a doctor immediately. If fluid contacts eyes or skin, rinse skin thoroughly with water.
- Read user manual instructions thoroughly before operating. Follow the instruction. Never remove warning or informative labels from the unit.

Important Safeguards

- Read all instruction
- Products for indoor use only.
Keep away from liquids. Never operate in rain or in damp conditions.
- Unit must be grounded.
- Don not open unit, risk of electric shock.
- Do not immerse in any liquid
- Save these instructions.



Caution!

There are no user serviceable parts inside this unit. Do not attempt any repairs yourself, doing so will void your manufactures warranty. In the unlikely event your unit may require service please contact your local dealer.



Particular Warning :

Please install the product correctly according to the instruction of the user manual. To avoid any accident, it is not allowed to install the product with any way not instructed on the user manual. If accident happens because users do not install the product according to the instruction of the user manual, the manufacturer will not take any responsibility.



Please note:

Specifications and improvements in the design of this unit and this manual are subject to change without any prior written notice.

Important

The wires in this mains lead are colored in accordance with the following code.



230V, 240V

Green and Yellow – Earthed (E)

Blue – Neutral (N)

Brown – Live (L)

Warning: This appliance must be earthed.

100V, 120V

Green and Yellow – Earthed (E)

White – Neutral (N)

Black – Live (L)

Warning: This appliance must be earthed.

Figure1 DMX HAZE Functions

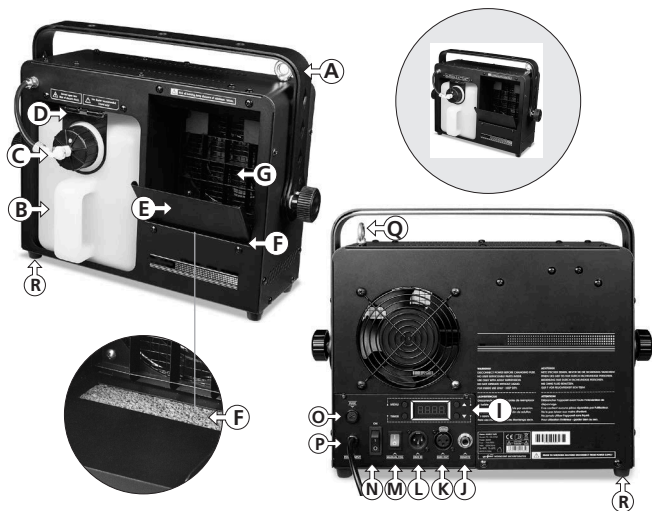

- A. Hanging Bracket with handle screw (used as a tripod)
- B. Tank
- C. Quick Connector
- D. Fixed Ring
- E. Air Deflector
- F. Sponge
- G. Smoke Output
- H. LED Display
- I. 4 Function Buttons
- J. Control Socket Connection
- K. DMX 3 pin XLR Output
- L. DMX 3 pin XLR Input
- M. Manual Fog
- N. Power ON/OFF
- O. Fuse
- P. Electric Power Input
- Q. Safety Ring
- R. Pad

Description

- Primary heating up takes very short time, only about 40 seconds, shorter than general haze machines.
- The innovative heating preservation function of the heater, under status of standby, heater keeps heating up steadily by lower temperature to protect the heating pipe to prolong the life.
- Drying, stable and smoothly smoke output control from 0-100%. High quality smoke, with smooth fan effect, so that the effect of smoke thinner and more uniform.
- The hanging bracket of the machine can be used as a tripod and do a variety of angles setting.
- Excellent design of 3-liter liquid tank has no worry of oil leaking when being operated up spray or forward spray. Quick connector makes replacement direct and easier when performance is ongoing.
- DMX on board, 3 DMX modes for choice; 1CH, 2CH, 4CH, operate by any additional DMX controller.
- Built-in multi-function operation control. Built-In timer control and continuous fogging control.
- Equipped with 0-90 degree adjustable air deflector.
- Heavy-duty. Able to keep working long time.
- Self-cleaning function: The machine design of machine stops working after a delay of 100 seconds, automatically clear the tubing of the remaining liquid.
- Easy understanding LED screen and intelligent design of software control.
- Could be used with the VT-1 controller (optional). Simple and user-friendly design makes MYSTYQUE 400 DMX easier to use.
- The streamline housing could be hanging, side hanging, landing installation, easy to set in various occasions.

Getting Ready

All products are thoroughly tested at the factory and shipped in perfect condition. If damage has occurred during shipping, or if components are missing, please contact your local dealer immediately.

Your package should include:

1. One DMX Hazer
2. One product user manual

Mounting

MYSTIQUE 400 DMX is shipped complete, ready to use. The bracket is installed before shipping, the unit can be hung in any position. Fasten the effect fan onto firm trussing (Use a 15-kg rated or stronger C-clamp bolted onto the bracket, enhancing safety necessarily with safety cables). Allow enough space (around 20cm) on all sides for proper cooling.

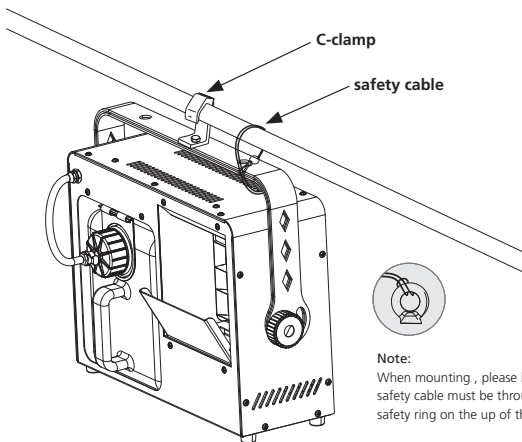

Note:

When mounting, please be sure the safety cable must be through the safety ring on the top of the machine.

Set Up

1. Open the shipping carton and carefully remove the unit from the shipping carton;
2. Be sure to remove packing material from around the haze machine, especially near the nozzle;
3. Set the haze machine on a dry, flat surface;
4. Connect the quick connector with the liquid tank cap (Figure 1-C). Be sure of well connection. Use definitely water based liquid of good quality;
5. Plug mains power cord from the haze machine into appropriate power supply socket. Wait about 40 seconds for heating element to heat up;
6. Use LED display for operating control, or connect DMX controller for setting;
7. Moving the machine during operation could probably get air entered into the liquid pipe and affect smoothness of fog blasts. If this happened, press the "Manual Fog" button to fog for a moment. Until the air is dispersed from the pipe, the machine will recover its normal fogging.

DMX Connector Pin Assignment

The machine provides a 3- or 5-pin XLR connector for DMX connection. The diagram below indicates pin assignment information.

5 pin XLR

XLR Male Socket

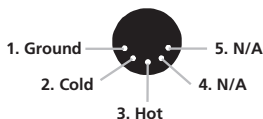

XLR Female Socket

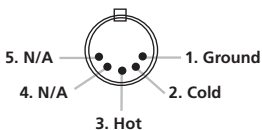

XLR Pin Configuration

- Pin 1= Ground
- Pin 2= Data Compliment (negative)
- Pin 3= Data True (positive)
- Pin 4= No use
- Pin 5= No use

3 pin XLR

XLR Male Socket

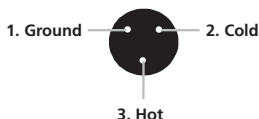

XLR Female Socket

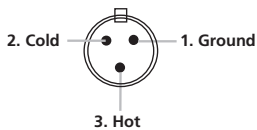

XLR Pin Configuration

- Pin 1= Ground
- Pin 2= Data Compliment (negative)
- Pin 3= Data True (positive)

Functions of the buttons

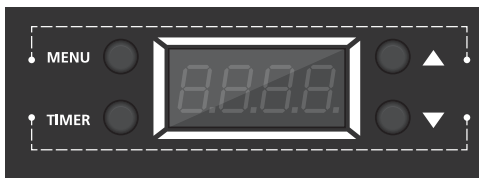

MENU: Function switching button; then have the numerical value changed by using UP and DOWN buttons.

DMX Address: Setting of DMX address. Range of address value: address=001~512.

A512

Press UP or Down 1.5 seconds can change value continuously and fast, pressed UP/DOWN at the same time, value back to 1.

DMX Mode: DMX mode selection. Single channel, 2 channels and 4 channels mode can be selected.

C001

Volume: Setting output of timing fogging and continuous fogging (Volume=5~100%).

U100

Interval: Setting interval of timing fogging (Interval=20-900s).

L020

Duration: Setting duration of timing fogging (Duration=10-200s).

1012

Heat Preservation: Setting duration of heating preservation (Duration = 1 min. -200 mins. – no limit). H200

H---

Under status of standby, duration of kept temperature of the heater, heater keeps heating up steadily by lower temperature to start fogging more quickly.

Fluid inspection ON/OFF: ON/OFF setting of automatic inspection of fluid volume.

F000

1. When this function is "0" means OFF, the machine cannot inspect volume of the fluid. This means that the machine will keep working even there's no fluid.
2. When this function is "1" means ON, the machine starts this inspection function automatically. Some points need to be paid attention to:
 - A. 80 seconds after being powered, the machine will inspect if there's fluid.
 - B. If the machine detects no fluid, it needs 30 seconds to do judgement to make sure there's no fluid, and then stop working. The display will show **no f**.
 - C. If the machine detects no fluid during operation, the machine stops working. At this moment, it is allowed to supplement fluid in the tank and then press "Manual Fog" button to let the machine enter working status again.

TIMER: Start and stop button for timing fogging.

UP: Button for increasing numerical value.

DOWN: Button for decreasing numerical value.



-
- Set values are automatically saved.
 - Self-cleaning function **PI CL**: When the machine stops fogging, please do not unplug the machine immediately, but wait 100 seconds to let the machine automatically clean the fluid left in the pipe. LED screen will show as picture and slow flash.
 - Standby **St by**: After the end of the pipe clearing, Standby will appear.
 - If fluid is run out, full the tank with fluid and press "Manual Fog" to reset.
-

Very Important

Please do not pull out the power suddenly when the machine is in normal smoke condition.



Control priority order:

When both DMX console and VT-1 are connected to the machine, appears problem of priority among the panel control, DMX console and VT-1 controller. There's no apparent priority among the three controls. The one which has change action gets the priority of control.

1. If DMX values changes of each DMX channel by DMX console, the control priority is DMX console.
2. If wanting VT-1 to have the control priority, turn the knob to OFF then to ON.
3. Pressing Manual Fog button or Timer button of the control panel to let it get the control priority.

Important: The one which controls the last action has the control priority.

Operation

1. Plug mains power cord from the haze machine into appropriate power supply socket;
2.  Primary power on, appear version number 1.9;
3.  2 seconds after, switches to working status: heating up;
4. Wait about 40 seconds for heating element to heat up;
5.  After heating up, displays the previous functions list before the last power off: The picture shows the new machine default state;
6. After the heating up is complete, Please do follow the required operating modes;

Continuous Fogging Operation



Panel control, DMX signal is not connected.

1. **U100** Press MENU to enter Volume adjustment, the picture shows the new machine default state;
2. **U020** Press "Up" or "Down" to adjust smoke volume value (1 -100%), the picture shows the volume value is 20%;
3. **☰020** Press Manual Fog to starts continuous fogging status, the red dot will run circularly;
4. **U020** Press Manual Fog again to stops continuous fogging status, the red dot disappears at the same time;
5. **Ⓟ CL** When the machine stops fogging, please do not unplug the machine immediately, but wait 100 seconds to let the machine automatically clean the fluid left in the pipe. This is to avoid causing negative effect when used next time. The LED screen will show as the picture, and letters are slow flashing;
6. **st by** After the end of the pipe clearing, Standby will appear.

Timing Fogging Operation





Panel control, DMX signal is not connected.

1. **L020** Press MENU to enter to Interval;
2. **L668** Press "Up" or "Down" to adjust the value of interval (20s-900s), the picture shows the Interval value is 668s;
3. **⌂012** Press again MENU to switch to adjust the value of duration, please note timing fogging still stops at the same moment;
4. **⌂058** Press "Up" or "Down" to adjust time value of duration (10s - 200s), the picture shows the Interval value is 58s;
5. And so on, you could also adjust the volume;
6. **☰055.** After setting the interval and duration, press Timer to start timing fogging, the display will shows decreasing in duration, and then shows decreasing in interval, continuous repeating cycle, the red dot will run circularly;

7.  002 Press again Timer to stop Timing fogging, red dot disappears at the same time;
8.  CL When the machine stops fogging, please do not unplug the machine immediately, but wait 100 seconds to let the machine automatically clean the fluid left in the pipe. This is to avoid causing negative effect when used next time. The LED screen will show as the picture, and letters are slow flashing;
9.  st by After the end of the pipe clearing, Standby will appear.

Remote Control Operation.....

For best result, use VT-1 wired controller.

1. Firmly attach the remote control mechanism to socket (Figure1-J) on the back of the unit;
2. Plug mains power cord from the machine into appropriate power supply socket, the red LED upon the controller is lighted;
3. The volume adjustment knob on the controller is with the switch;
4. Turn the knob counterclockwise to the end to switch off, the fog is off, the green LED upon the controller is lighted;
5.  000 The LED screen of the haze shows as left picture;
6. The volume adjustment knob clockwise adjustment volume increases, counterclockwise adjustment volume reduction, the green LED upon the controller is blinking;
5.  0.07 The LED screen of the haze shows the increase and decrease correspondingly with adjusted by controller, the red dot will run circularly;
8.  CL When the machine stops fogging, please do not unplug the machine immediately, but wait 100 seconds to let the machine automatically clean the fluid left in the pipe. This is to avoid causing negative effect when used next time. The LED screen will show as the picture, and letters are slow flashing;
9.  st by After the end of the pipe clearing, Standby will appear.

VT-1 wired controller



A-1/4" stereo jack

B- Knob

C- Green LED (Volume output)

D- Red LED (power)

Controller power cord length: 3 m;

Connector: 1/4 "stereo jack;

Function: Air volume adjustment & ON/OFF;

Model	VT-1
Cable Length	3m
Effective Distance	N/A
Connector	1/4" stereo jack
Function	ON/OFF Volume adjustment
Dimension (LxWxH)	90 x 50 x 39 mm
Weight	0.257 kg

DMX Control Operation

1. Setting DMX mode and DMX address by function buttons (figure 1-l) on both side of the LED screen, DMX operation has not started at this time;
2. **C001** Press MENU enter to DMX mode, press Up or Down button to set the DMX Mode, there are 3 DMX modes for choice: 1CH, 2CH, 4CH;
3. **A512** Press MENU enter to DMX address, press Up or Down button to set the DMX address;
4. Connect the DMX 512 controller cable to the input socket (figure 1-L) of the machine unit. Make sure the signal cable polarity is correct. When DMX socket receives effective DMX signals, the machine enter DMX control mode automatically, other built-in functions still valid (please refer to control priority order);
5. **≡100** When received DMX signal, the three lines in the left will blinking;
6. The values on the LED screen will change correspondingly with adjusted by the DMX controller;
7. During the DMX operating (DMX signal has been received and began to work) still can switch DMX mode and change DMX address, please press Up/Down to switch DMX mode to 2 channel or 4 channel and to change the address;
8. If desired, connect another haze machine: Plug one end of another signal cable in to the output socket (figure 1-K) on the back of the first machine; plug the other end of the signal cable to the input socket (figure 1-l) on the back of the second machine. Follow the same procedure to link more machines, if desired. Whole link is daisy chain;
9. Down. Refer to DMX channel chart in Figure 2 make related settings. Now start operating the machine with DMX console.



-
- Upon receiving DMX signal, all built-in functions still valid.
 - Set values are automatically saved.
 - Self-cleaning function: When the machine stops fogging, please do not unplug the machine immediately, but wait 100 seconds to let the machine automatically clean the fluid left in the pipe. LED screen will show **PI CL** and slow flash. After the end of the pipe clearing, Standby will appear, LED screen shows **St by**.
-

Figure 2 DMX Chart

1 CH

CH1	
DMX Value	Volume
0-255	0%-100%

2 CH

CH1		CH2	
DMX Value	Volume	DMX Value	ON/OFF
0-255	0%-100%	128-255	ON
		0-127	OFF

4 CH

CH1		CH2		CH3		CH4	
DMX Value	Volume	DMX Value	ON/OFF	DMX Value	Duration	DMX Value	Interval
0-255	0%-100%	128-255	ON	10-255	10-255s	2-255	20-2550s
		0-127	OFF	0-9	0s	0-1	0s

**s=seconds.

**Interval =0 means constant fog.

** When the smoke state is off (volume =0), the timer does not work, the LED screen of the machine shows values of interval and duration which are the parameters set by the DMX console; when the smoke state is on (volume=1%-100%), the timer works, the interval and duration values shows by LED screen are decreased by second, this process will always be cycled.

Troubleshooting

This troubleshooting guide is meant to help solve simple problems. If a problem occurs, carry out the steps below in sequence until a solution is found. Once the unit operates properly, do not carry out following steps. If the problem persists, refer servicing to a qualified technician.

Power Connected but No Smoke is Emitted:

1. Check the power supply. Plug the unit into grounded electric power supply socket with proper voltage.
2. Disconnect the machine from electric power supply. Replace fuse with one of the same type.
3. Keep sufficient fluid in tank.
4. Check if pump is working (with fluid flow or not).
5. Check if the heater is heating (touch the panel to see if it is warming).
6. Check your controller if in correct connection.
7. Check your DMX address setting.

Power Connected, Fog Blasts not Smooth:

Moving the machine during operation could probably get air entered into the liquid pipe and affect smoothness of fog blasts. If this happened, press Manual Fog button to fog for a moment. Until the air is dispersed from the pipe, the machine will recover its normal fogging.

Should there be any low fog emitted, running noisily or hindered fogging, please wait for self-cleaning and pull out the plug immediately. Check if string enough fluid, if the pipe connected to the tank is clean, if there's air inside the pipe, if the liquid flows, if not, plug-in again; still persists abnormal running, and If causation

is unclear, stop running to avoid any damage, shut down to cool it, and bring unit to your local agent or appointed service place for inspection, prohibit any dismantlement by yourself.



- If fluid is run out, full the tank with fluid and press “Manual Fog” to reset.
-

Very Important:

Please do not pull out the power suddenly when the machine is in normal smoke condition.

Maintenance

Before doing maintenance, please make sure that the power is cut, the power cord is unplugged, and the machine itself has cooled down.

The maintenance must be done by qualified person.

1. The fluid is not allowed to get dirty. Be sure to always clean or replace the caps on the tank (Replace the caps on the tank directly. This kit includes quick connector, cap, pipe and filter) and tight the cover of the haze machine tank immediately after filling.

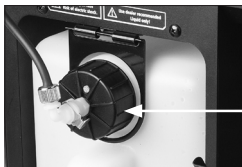

2. Prolonged use, the nozzle may be clogging by impurities, periodically use tools to clean the nozzles, keep the nozzle unobstructed.
3. Prolonged use, please clean the air inlet regularly.
4. Prolonged use, sponge inside the vent may accumulate oil, periodically cleaned out or replaced with a new sponge.

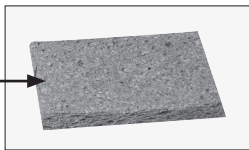
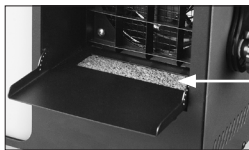

5. Periodically check the connections among the oil tube, the pump and the heater to see if there's oil leaking. If positive, lock tight the connections carefully with proper tool.
6. PC board should be kept from being dirtied with oil. In case this happened, dismantle carefully the PCB, and have it brushed clean both sides with dilute alcohol. Leave it dry itself, then install it back. Make sure all wires are well connected.
7. Clean the metal cover with dry cloth.

Product Specifications

Model No.	MYSTIQUE 400 DMX
Heater Power	450W
Consumption	465W
DMX512 CH.	1CH, 2CH, or 4CH
Built-in Function	<ul style="list-style-type: none"> • Timing Fogging • Continuous Fogging
Fuse (100V, 120V)	250V 6.3A
Fuse (230V, 240V)	250V 4A
Display	LED Screen
Tank (liters)	3L
Fog Output (cu.ft/min)	4000
Warm Up time(seconds)	40s
Fluid Consumption (ml/min)	4.5ml/min
Date Connection	3P XLR
Low Fluid Shutdown	Yes
Bracket	Yes
Voltage	100V 50/60Hz; 120V/60Hz; 230V,240V/50Hz
Dimensions/mm (LxWxH with bracket)	414x202x303mm
Weight (kg)	4.5kg
Controller (Optional)	VT-1

* Voltage is preset at the factory and may not be changed.

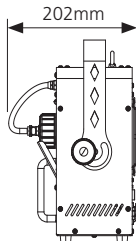
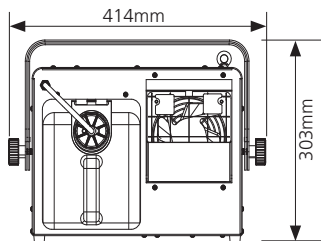

MYSTYQUE 400 DMX

Save this instruction properly

All the information is subject to change without prior notice